

## Contents

Table Of Contents	
About Mini Multipurpose Machine	2
1. An Ideal Tool.	2
2. Machine Characteristics.	3
3. General Caution and Warning.	3
Part List Of 8 in 3 Kit Set.	5
Part List Of 6 in 1 Kit Set.	6
Parts figure.	8
Parts Assembly And Operation.	13
1. Motor And Gear Box.	13
2. Small Slide And Large Slide.	14
3. Small Slide And Intermediate Connection Piece.	14
4. Three-jaw Chuck.	15
Assembly And Operation Of Mini Multipurpose Machine	16
1. Jig Saw.	16
2. Lathe.	18
3. Woodturning lathe.	20
4. Drilling Machine.	22
5. Milling Machine.	24
6. Sanding Machine.	26
7. Hand-held Machine.	27
8. Drilling Machine With Dividing Attachment.	28
How To Fasten The Machine On The Table.	30
Important Technical Parameters	31
Trouble Shooting.	34
Model Samples.	36

**The enterprise objective:**  
**Integrity management, Seeking for greater perfection**  
**Service concept:**  
**Leading technology, Education services**

## 1. An Ideal Tool

### 1. Hobbyist and DIY Enthusiasts

Taking the advantages of the tools' flexibilities and cost effectiveness, hobbyist and DIY Enthusiasts can easily put your design into practical things.

### 2. Model-makers

It is not practical to use a big machinery building and developing prototype. The mini tools can Satisfy model-makers' needs and they can scale up the final prototypes into products on completion of the prototyping concept.

### 3. Children

Most children enjoy making handcraft in a team. As a result, this would educate the children to be aware of the importance of team works. Lacking of mental concentration is common for children. Certain efforts and skills are required to put into make handcraft and our tools would help children to build up concentration.

### 4. Causal and Leisure Groups

People like to work together to enjoy a lovely moment to produce something that can bring someone's memories forever.

Practical : Do it yourself ,realize the ideal

Safe : Don't hurt the operating personnel

Inspire intelligence    Inspire creativity

Convenient : Save spaces,disassembling easily

Economic : Multipurpose

## 2. Machine Characteristics

The followings are our machine characteristics:

### 1) Occupy Little Space

Our machine can be operated in a small space, even on your dinner table. When finished, you can also place it in your drawer.

### 2) Safety Features

1. Our special design on 12VDC motor, it can reduce any known dangers for operator.  
2. Operating Jigsaw is completely safe for children aged 10 or above. When someone touches or holds the blade with fingers while the jigsaw is in motion, fingers will not get hurt other than the feelings of the blade vibrations. However, other machines are safe enough when the operators follow our safety instructions as stated in our operational instructions. Thousands of people have joined in Zhouyu workshops every year, and no injure case has been reported so far as we are concerned. Obviously, improperly operation can cause serious injure.

### 3) Cost Saving

Cost saving can be achieved on our 6 in 1 and 8 in 3 kit. You can assemble various machines, such as Lathe, Jigsaw, Milling Machine, Drilling Machine, Sanding Machine, Woodturning Lathe, etc., Each machine will have different functions.

6 in 1 kit- you can operate one (1) machine in one time and you can assemble up to 6 types of machines

8 in 3 kit - you can operate three (3) machines concurrently and you can assemble up to 8 types of machines

### 4) No Major Differences on Professional Machine

Theoretically, there is no difference between Zhouyu Machine and real-size (professional) Machine. Our machine has the common individual parts, such as, motor, chuck, slide, etc. as the professional machine, and both operation is almost identical. The differences are in precision and machine size. Most importantly, it is the price that we are offering is much less than the real-size machine.

### 5) Handling Wood and Soft Metal

Our machine can handle wood, such as Larch, Birch, Beech, Ash-tree, Lime-tree, Poplar, etc., And working on hardwood is particular suitable. Other than wood, our machine can handle soft metal, such as, Brass, Copper, Aluminum, Precious metals (Gold, Silver). Iron and Steel are too hard for Zhouyu machine.

## 3. General Caution and Warning

You need to read the manual carefully before operating Zhouyu mini multipurpose machine. General Safety warning and operation caution are listed as following which cover the whole procedures of operation, maintenance, inspection and cleaning. Further cautions and warnings can be viewed under each machine operation instructions. Proper operation will make your work easier. The followings are the general safety cautions:

- 1) Keep the work place ventilated. Work in the clean and dry condition, do not in wet and dirty condition.
- 2) Keep the children (under age 14) away from the working area.
- 3) Store the machine in the place where children can not reach.
- 4) Always wear the goggle to protect your eyes when you are operating the machine.
- 5) Keep hair and clothing far away from moving parts.
- 6) Stop the machine instantly when anomalous sound is heard, work again after the reason is found and fixed up.
- 7) Always check the machine before you start operating it, shift or replace the worn parts if required. As some of the components are designed specially for our machine, you are advised to use our components avoiding injury and extending the life time of your machine.
- 8) Keep away from chemical and explosive while operating.
- 9) Our manual has not covered all the conditions that you may be confronted. Nevertheless, common sense and safely awareness are the most importance.
- 10) Some of the images shown in the manual are in different scale in comparison with the real-size.

**The followings are the general operation cautions:**

- 1) Tighten the parts after adjustment or placement between other parts.
- 2) Avoiding accident, press the adaptor switch to "off" before starting to operate. The adaptor must be in ventilated and dry surrounding.
- 3) Hold the tools tightly when processing the workpiece.
- 4) Never touch the revolving workpiece, particularly the revolving tools with any part of Your body.
- 5) Due to the experience limitation of the junior operator, beginner do not feed too fast. You can adjust feed speed according to your requirement when you are skilled.
- 6) When the motor stop or obviously slow down for resisting force, cut the power supplier immediately within 5 seconds and do not delay to shut off the machine, otherwise, the motor will be destructive. When this happens, check the reason and fix it before restaring the machine.
- 7) Pull out the adaptor after finishing your work.
- 8) Keep the machine clean and dry. Lubricate the movable components timely.
- 9) View the hind manual for more cautions of each machine.

### 8in3 Part List

Description	No.	Q'ty	Unit	Description	No.	Q'ty	Unit
Long Machine Bed	Z002	2	PCS	Toothed Belt	Z031	3	PCS
Short Machine Bed	Z003	3	PCS	Belt Cover	Z032	1	PCS
Extra Long Machine Bed	Z001	1	PCS	Woodturning Support	Z033	2	PCS
Motor	Z006	3	SET	Grinding Wheel Cover	Z034	1	PCS
Wheel Gear Box	Z004	3	SET	Grinding Wheel Cover Connector	Z035	1	PCS
Tailstock	Z007	2	SET	Center needle	Z036	2	PCS
Small Slide	Z008	3	PCS	Pad(0.3mm)	Z037	20	PCS
Large Slide	Z009	2	PCS	Lathe Tools Fastener	Z038	1	PCS
Longitudinal Slide	Z010	1	PCS	Stabilizing Plate	Z08001	2	PCS
Three-Jaw Chuck	Z011	1	SET	Right Angle Stabilizing Plate	Z08003	2	PCS
Vice	Z012	1	PCS	Protective Goggle	Z040	1	PCS
Dovetail Connecting Block	Z013	18	PCS	Slot Nut	Z042	28	PCS
Jig Saw Case	Z014	1	PCS	Two Hole Clamping Plate	Z043	16	PCS
Cam	Z015	1	PCS	Lathe Tool Fixer	Z044	7	PCS
Drive center	Z016	2	PCS	Collet Fixing Nut	Z045	4	PCS
Clamping Plate	Z017	1	PCS	Screwdriver	Z070	2	PCS
Grinding Wheel	Z01801	1	PCS	Socket Screw Wrench	Z071	2	PCS
Grinding Wheel Assy.	Z01802	2	PCS	Rod	Z072	2	PCS
Life center	Z019	2	PCS	Center Finder	Z073	2	PCS
Power adaptor	Z020	1	PCS	φ2 Drill Bit	Z07401	1	PCS
Dividing Positioner	Z022	1	SET	φ3 Drill Bit	Z07402	1	PCS
Dividing Attachment	Z023	1	SET	φ3 milling tool	Z07501	1	PCS
Sanding Paper	Z024	10	PCS	φ6 milling tool	Z07502	1	PCS
Sawing Table	Z025	1	PCS	Lathe Tool	Z077	1	PCS
Drilling Table	Z026	1	PCS	Turning Gouge	Z078	1	PCS
Drilling Lever	Z027	2	PCS	Saw Blade	Z060	20	PCS
Press Plank	Z028	1	PCS	Collet Set(8pcs)	Z061	2	SET
Jig saw Base	Z029	1	PCS	Standard Hardware	Z065	1	SET
Intermediate Piece	Z030	6	PCS	Grinder Tools	Z062	1	SET

### 6in1 Part List

Description	No.	Qty	Unit	Description	No.	Qty	Unit
Long Machine Bed	Z002	1	PCS	Toothed Belt	Z031	2	PCS
Short Machine Bed	Z003	1	PCS	Belt Cover	Z032	1	PCS
Mbtor	Z006	1	SET	Woodturning Support	Z033	1	PCS
Wheel Gear Box	Z004	1	SET	Grinding Wheel Cover	Z034	1	PCS
Tailstock	Z007	1	SET	Grinding Wheel Cover Connector	Z035	1	PCS
Small Side	Z008	2	PCS	Center needle	Z036	1	PCS
Large Side	Z009	1	PCS	Pad(0.3mm)	Z037	10	PCS
Three-Jaw Chuck	Z011	1	SET	Lathe Tods Fastener	Z038	1	PCS
Vice	Z012	1	PCS	Stabilizing Plate	Z08001	2	PCS
Dovetail Connecting Block	Z013	6	PCS	Right Angle Stabilizing Plate	Z08003	1	PCS
Jig Saw Case	Z014	1	PCS	Protective Goggle	Z040	1	PCS
Cam	Z015	1	PCS	Slot Nut	Z042	10	PCS
Drive center	Z016	1	PCS	Two Hole Clamping Plate	Z043	10	PCS
Clamping Plate	Z017	1	PCS	Lathe Tool Fixer	Z044	4	PCS
Grinding Wheel	Z01801	1	PCS	Collet Fixing Nut	Z045	1	PCS
Grinding Wheel Assy.	Z01802	1	PCS	Screwdriver	Z070	1	PCS
Life center	Z019	1	PCS	Socket Screw Wrench	Z071	1	PCS
Power adaptor	Z020	1	PCS	Rod	Z072	2	PCS
Sanding Paper	Z024	5	PCS	Center Finder	Z073	1	PCS
Sawing Table	Z025	1	PCS	φ2 Drill Bit	Z07401	1	PCS
Drilling Table	Z026	1	PCS	φ3 milling tod	Z07501	1	PCS
Drilling Lever	Z027	1	PCS	Lathe Tod	Z077	1	PCS
Press Plank	Z028	1	PCS	Turning Gouge	Z078	1	PCS
Jig saw Base	Z029	1	PCS	Saw Blade	Z060	10	PCS
Intermediate Piece	Z030	2	PCS	Collet Set(8pcs)	Z061	1	SET
				Standard Hardware	Z065	1	SET

8in3 Kit Set

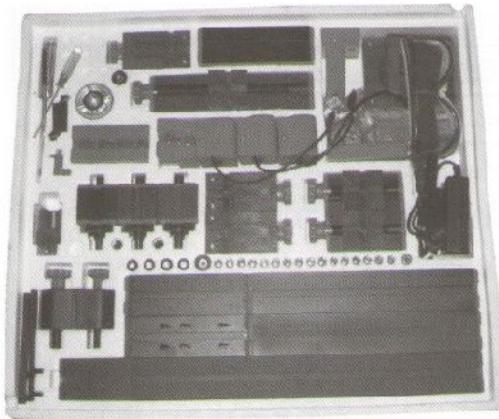

8in3

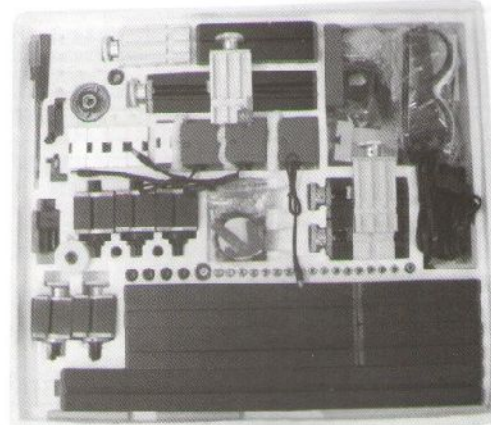

Metal 8in3

**NOTICE:** The total parts of 8in3 kit(Z8000) can be assembled into maximum 8 kinds of different machine tools, such as Jig-Saw, Lathe, Woodturning Lathe, Drilling Machine, Milling Machine, Sanding Machine, Hand-held Machine, Drilling Machine With Dividing Attachment. However in the same time, the total parts are only available to be assembled for any three kinds of the Eight.

6in1 Kit Set

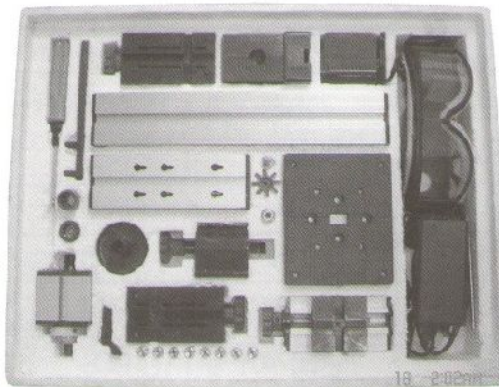

6in1

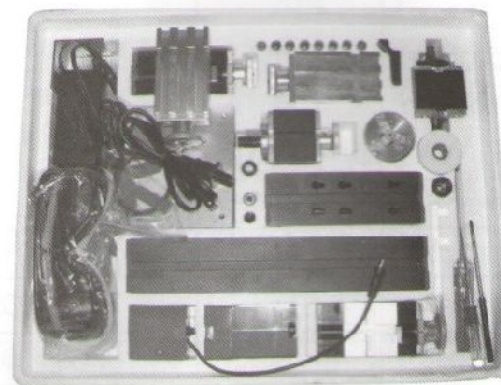

Metal 6in1

**NOTICE:** The total parts of 6in1 kit(Z6000) can be assembled into maximum 6 kinds of different machine tools, such as Jig-Saw, Lathe, Woodturning Lathe, Drilling Machine, Milling Machine, Sanding Machine. However in the same time, the total parts are only available to be assembled for one kind of the Six.

## Parts figure

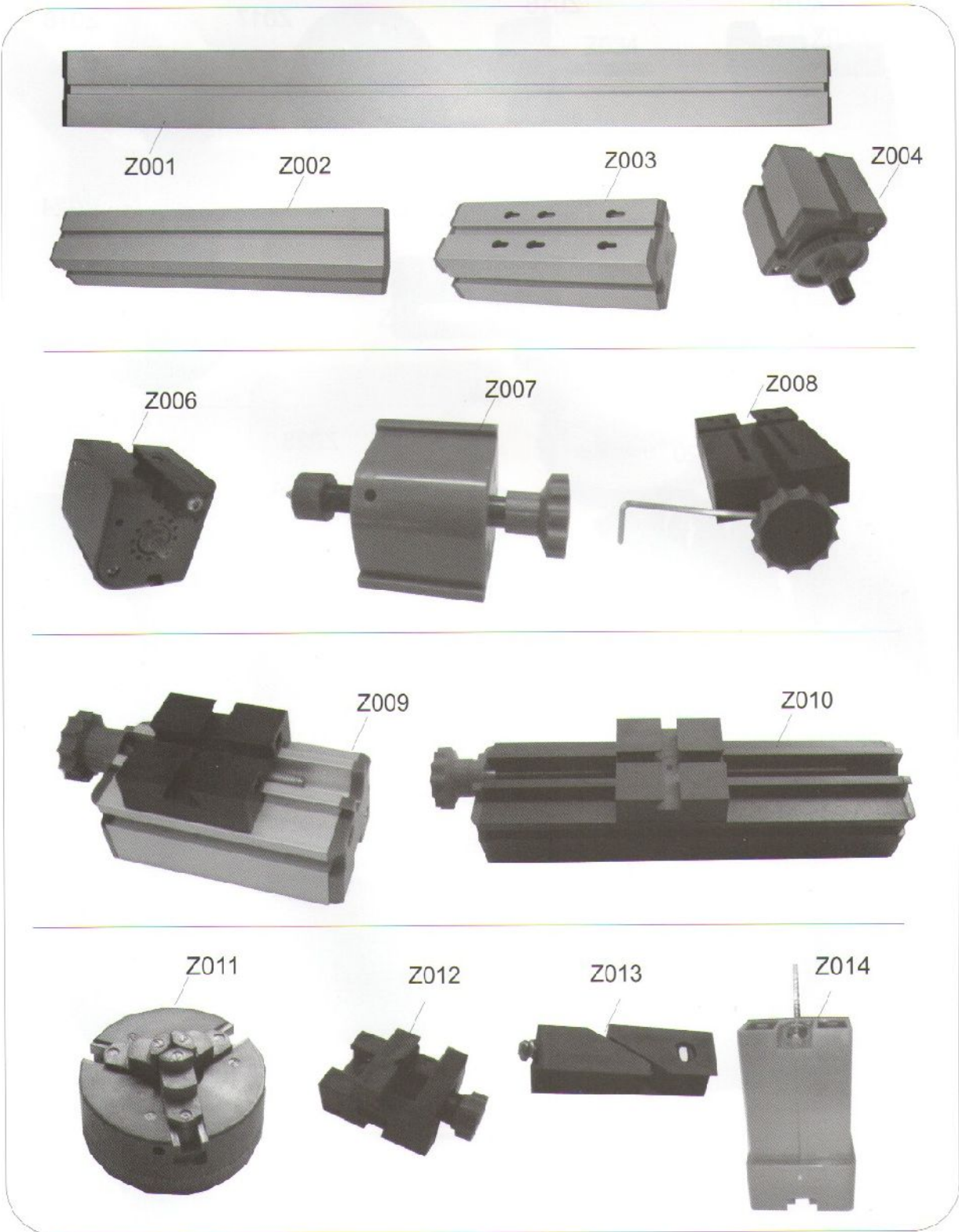



## Parts figure

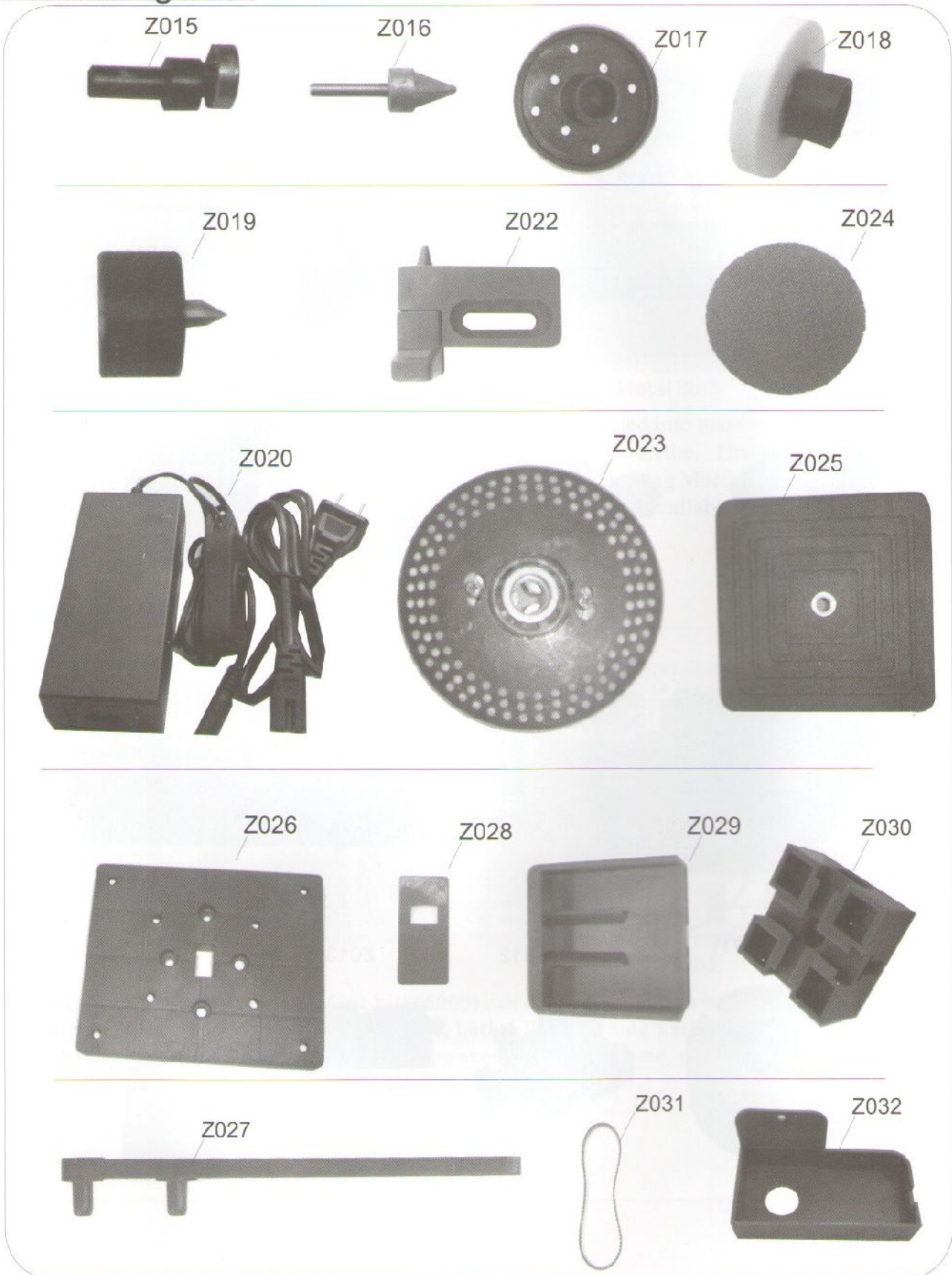

## Parts figure

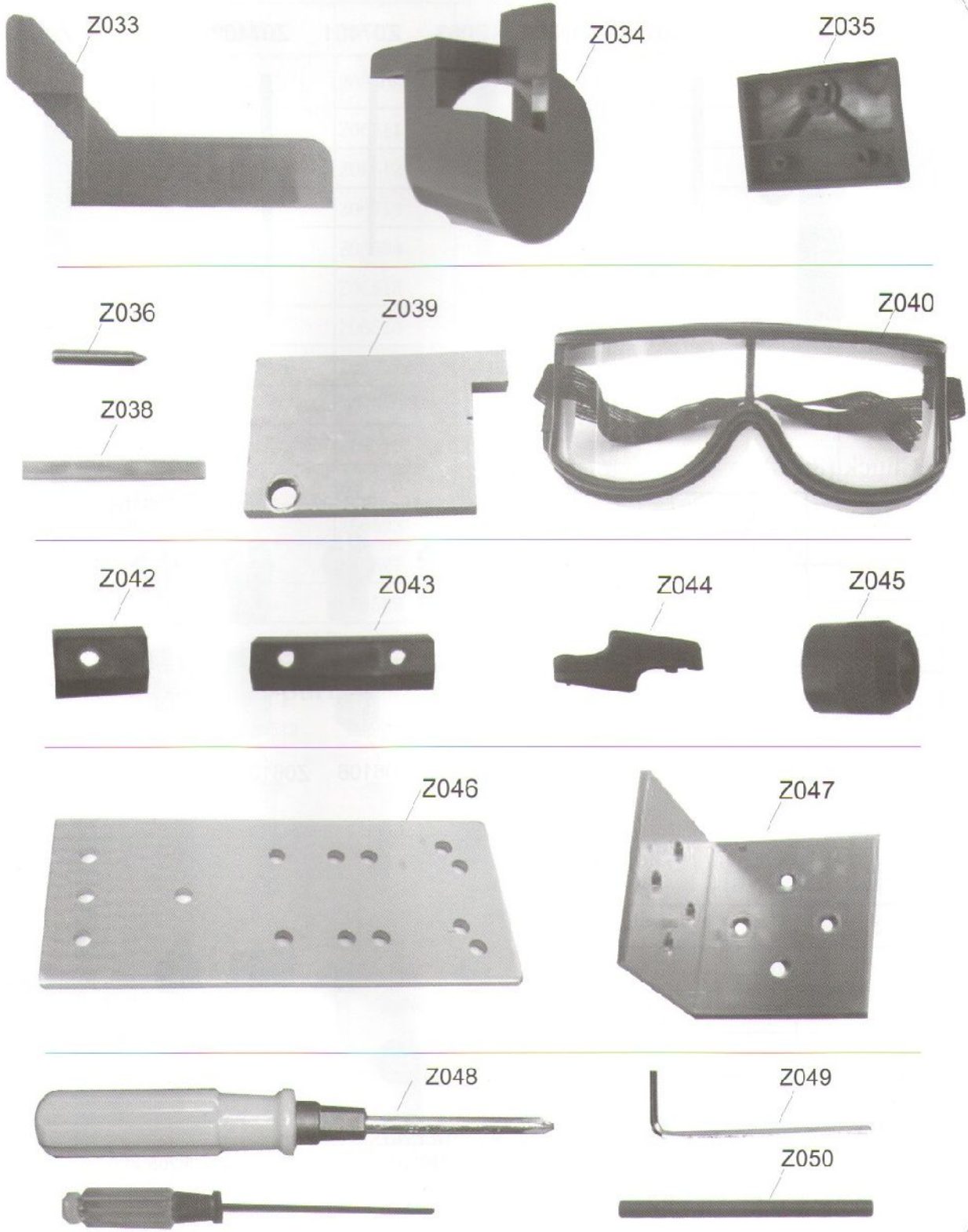

## Parts figure



### Chuck (8pcs)

Z061	Z06101	φ 1mm
	Z06102	φ 2mm
	Z06103	φ 2.5mm
	Z06104	φ 3mm
	Z06105	φ 3.5mm
	Z06106	φ 4mm
	Z06107	φ 5mm
	Z06108	φ 6mm



### Burnish suite(7pcs)

Z062	Z06201	Cylinder
	Z06202	Cone
	Z06203	Round ball
	Z06204	Disc
	Z06205	Semieircle sphere
	Z06206	Wool
	Z06207	Metal wire

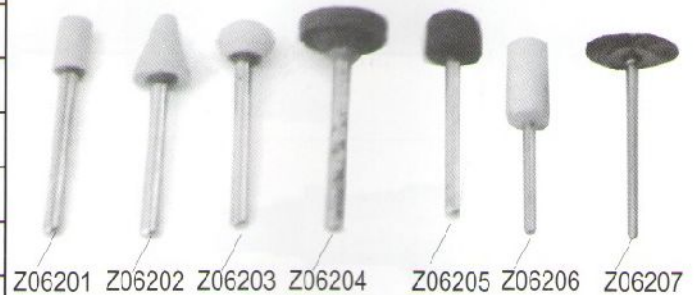

Z065	Z06504	M3x10	Self tapping screws
	Z06508	M3x16	Screw
	Z06511	M2x10	Screw
	Z06512	M4x7	Screw
	Z06513	φ 8. 8X4. 2X0. 6	gasket
	Z06534	φ 12X4. 2X0. 6	gasket
	Z06515	M4x8	Screw
	Z06516	M4x10	Screw
	Z06517	M4x12	Screw
	Z06518	M4x14	Screw
	Z06519	M4x16	Screw
	Z06520	M4x25	Screw
	Z06523	M3x40	Screw
	Z06527	M3	Six hexagon nut
	Z06529	M4	Six hexagon nut

**Screw Standard parts:**



## Parts Assembly And Operation

### 1. Assembly And Operation Of Motor-Wheel Gear Box Unit (Z1):

The followings are steps for assembling the Motor-Wheel Gear Box Unit(Z1):  
As shown in Fig 1:

- Slide the Dovetail Connecting Block (Z013) into the Motor(Z006). After inserting the Dovetail Connecting Block into the Motor, connect the Motor with the Wheel Gear Box (Z004) by sliding the Connecting Block into the groove of the Motor as shown in Fig.9. Once both the Motor and the Wheel Gear Box are in the corrected position, fasten and tighten the Connecting Block to hold the Motor and the Wheel Gear Box together.
- Fit the toothed belt (Z031) into the Motor and Gear Box.
- Finally, the Motor-Wheel Gear Box Unit (Z1) has been assembled. Adjust the belt tension by tightening or loosening the screw of the motor with a Screwdrivers (Z070) as shown in the diagram.
- Ensure the belt having the right tension as the belt has major influence on the motor and work performance. It is very important for adjusting the tension of the drive belt before starting the motor.
- The motor rotating direction is clockwise while face to the motor leaf's slice.
- Use the nut and bolt (Z065) to fasten the driver belt cover (Z032) onto the motor to protect the toothed belt in most situations.

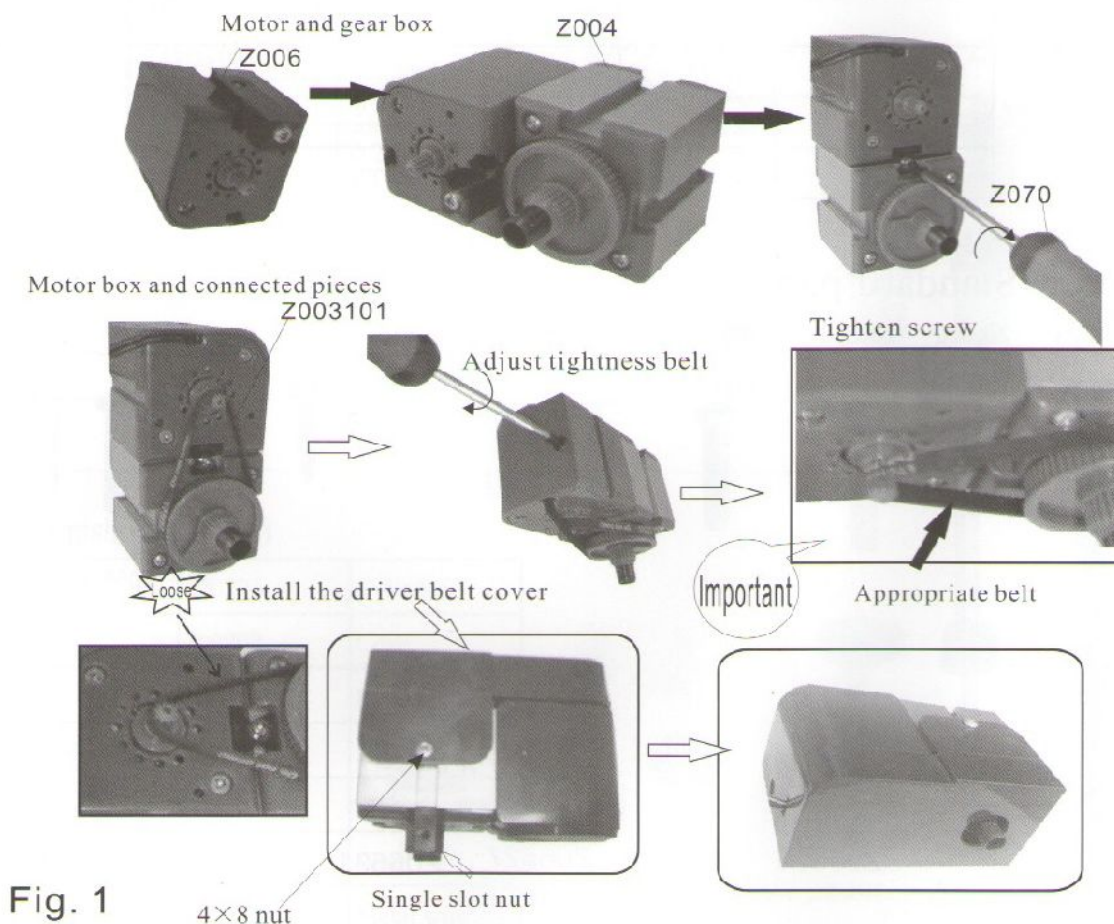
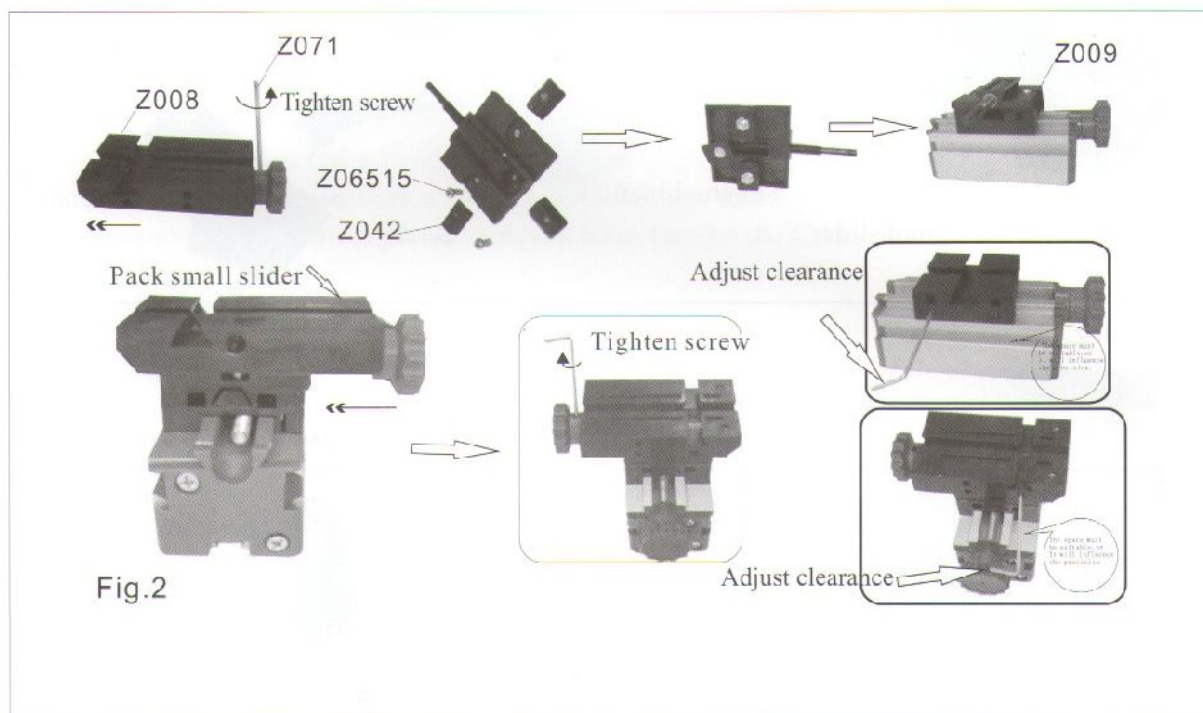

Fig. 1

## 2. Assembly And Operation Of Small Slide (Z008) And Large Slide (Z009) Unit (Z2)

As shown in Fig :

- ✎ Hold the Small Slide (Z008) tightly, use the Socket Screw Wrench (Z071) to loosen the bolt in the position as shown in the diagram. After that, push the base of small slide out. Slide three Greased Slot Nuts (Z042) into the dovetail groove of the Large Slide (Z009). Then, fix the Small Slide base on the Large Slide by tightening the bolts into the three Slot Nuts.
- ✎ Place the other parts of the Small Slide on the base, use the Socket Screw Wrench to tighten the bolt in the handle. When the above adjustment is done, the Small Slide and the Large Slide Unit (Z2) have completed as shown in the diagram.
- ✎ Grease the movable sections as required, such as bolt, dovetail groove of small slide, Large slide, etc.



## 3. Assembly And Operation Of Small Slide (Z008) And Intermediate Piece (Z030) Unit (Z3)

As shown in Fig 3:

- ✎ Use the Socket Screw Wrench (Z071) to loosen the bolt in the handle of the Small Slide (Z008). Then, push the base of Small Slide out.
- ✎ Slide three slot nuts (Z042) into the dovetail groove of the Intermediate Piece (Z030), fix the Small Slide base on the Intermediate Piece by tightening the bolts into three slot nuts.
- ✎ Replace the other parts of the Small Slide on the base, tighten the bolt in the handle by Socket Screw Wrench.
- ✎ Completing above steps, the Small Slide-Intermediate Piece Unit (Z3) has been assembled as shown in the diagram.
- ✎ If you are working with tilted slide, you may need to tighten slide base to the intermediate piece in a desired angle as shown in the diagram.

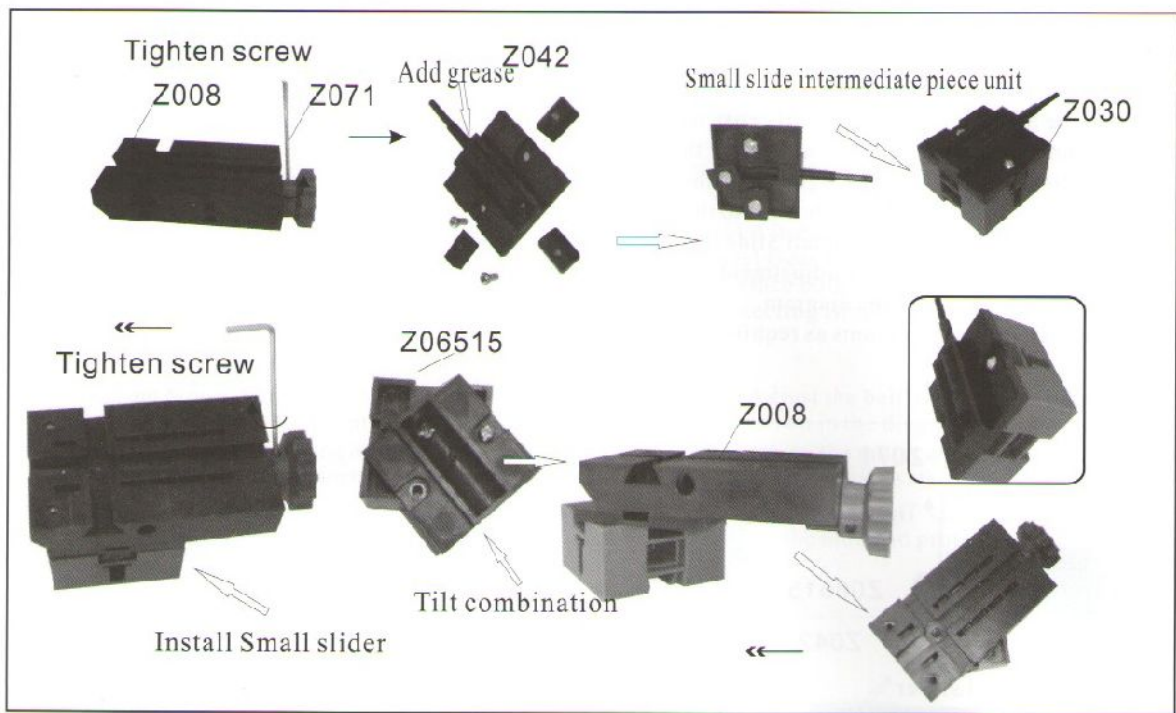

Fig.3

#### 4. Operation Of Three Jaw Chuck (Z011)

The assembly method of jaw for small workpiece

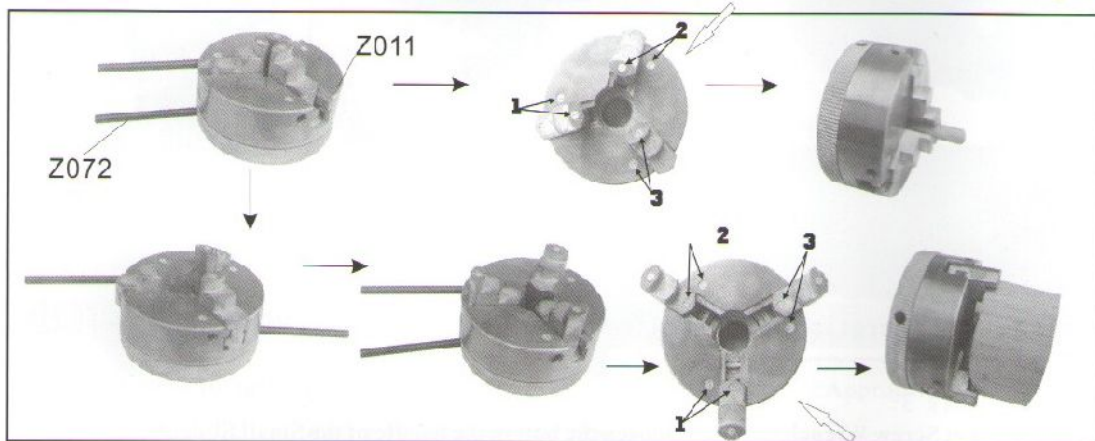

Fig.4

The assembly method of jaw for big workpiece

As shown in Fig 4:

Place the rods (Z072) into the hole of Three Jaw Chuck (Z011), use the rods to rotate the chuck that makes the jaws to open or close.

Working on a bigger diameter work piece with the chuck, you need to rotate the chuck until the jaws drop out. As soon as the jaws dropped out, reverse the jaws into the chuck.

The position of the numbers of jaw must be corresponding to the chuck top, i.e. Clamp small work piece using inner jaws, while Clamp big work piece using outer jaws.

## Assembly And Operation of mini Multipurpose Machine

### Jigsaw (Z20001)

#### Assembly:

As shown :

Fix the Intermediate Piece(Z030) on Short Machine Bed (Z003) by Dovetail connection Block (Z013).

Fasten Motor-Wheel Gear Box unit(Z1) on the Intermediate Piece.

Install the Cam(Z015) into the Wheel Gear Box with Collet(Z06106) and Collet Fixing Nut(Z045); measure the extension of Cam with Press Plank (Z028);

Then slide Jigsaw Case(Z014) into Jigsaw Base(Z029), and slide the Press Plank into to the groove of Jigsaw Base. Fasten them on Short Machine Bed.

Assemble the Saw Blade(Z060) in Jigsaw Case, then fix the Jigsaw Table (Z025) on the Jigsaw Case.

At last, assemble the Belt Cover(Z032).

#### Operation:

The Jigsaw is not dangerous at all! For the small stroke(only 4mm) of the Saw Blade the skin only vibrates. You may press the workpiece both sides on the Jigsaw Table, drag the workpiece opposite to blade teeth, when you are cutting the workpiece.

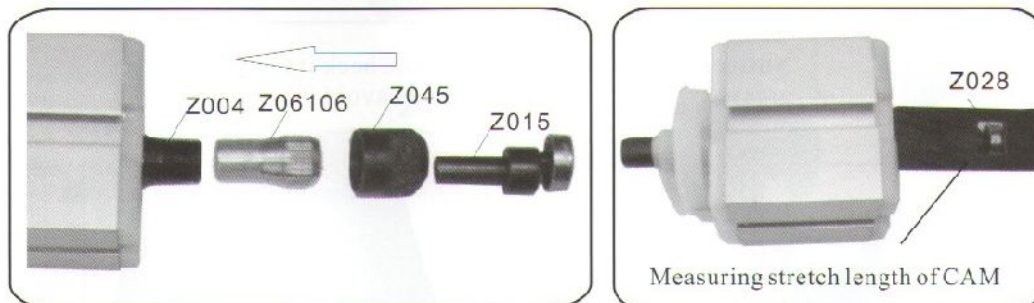



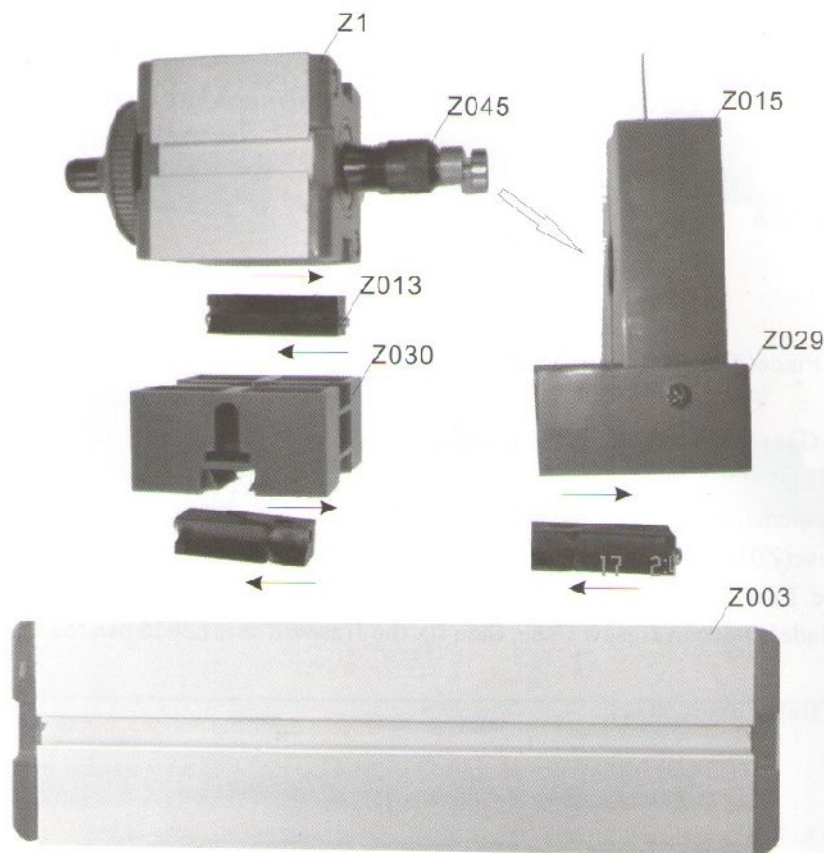

Add grease  
(Vasclinc, butter)

**Notice:** Once the noise is too load, Check if there is still grease. Grease this place in time to avoid the damage of the machine.

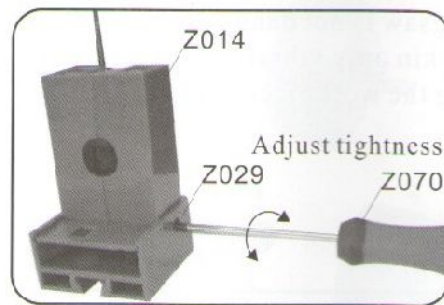

Adjust tightness  
Z029 Z070

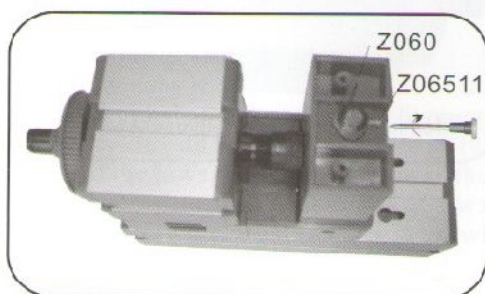

Tighten screw



The method of changing saw blade as shown above.

## Lathe (Z20002)

### Assembly:

As shown Fig:

Fix Motor-Wheel Gear Box unit(Z1) on the left of Long Bed(Z002) by Dovetail Connecting Block(Z013),screw Three Jaw Chuck(Z011) into axle of Motor-Wheel Gear Box unit(Z1).

Fix Small Slide-Large Slide unit on the obverse of long machine bed.

Fasten Lathe Tool Fastener(Z038)) beside Small Slide with 4×25mm bolt(Z06520).

Fasten Lathe Tool(Z077) on the left corner of Small Slide by Lathe Tool Fixer(Z044), You can adjust the height of tool by 0.3 Pad(Z037).

Fix Tailstock(Z007) on the right of Long Machine Bed, screw Live Center(Z019) into tailstock.

In order to reinforce the connection of the machine, you may use two fastener Stabilizing Plates(Z08001) to achieve it: fix fastener Stabilizing Plates on Wheel Gear Box, Long Machine Bed, Tailstock with Two Hole Clamping Plate(Z043). After all are finished, assemble Belt Cover(Z032) with Slot Nut(Z042).

### Operation:

Make sure workpiece has been clamped tightly before working, otherwise it will fly out and cause unexpected harm! Never touch the revolving working piece with any part of your body and your clothes, and wear goggles! Always adjust the height of Lathe Tool with workpiece axis. Sharp tool with grinding wheel following the operation of sanding machine. If you process large diameter work piece with lathe(Max Dia. 50mm), you may heighten wheel gear box, tailstock, small slide with Intermediate Piece(Z030). If the stroke of large slide is too short to do with demand, Adjust the position of large slide that responding to long machine bed.

### Notices:

Firmly adjust the free movement of slides(they should move without stop) in order to enhance precision .The Lathe Tool must be positioned exactly at the height of the rotational axle of the work piece(usually a plate(Z037) will fit).

The groove of Lathe Tool Fixer is similar to the width of Lathe Tool so that Lathe Tool is pressed on the small slide and hard to move! ( See Fig.15).

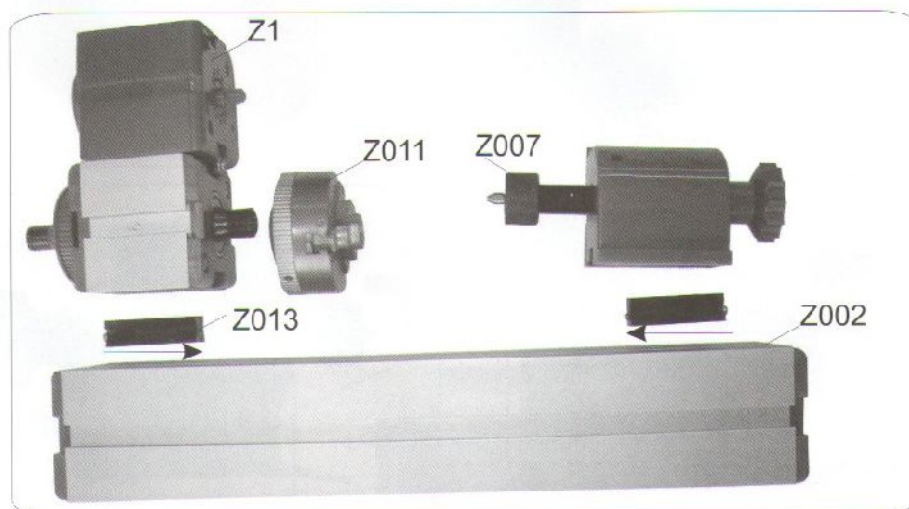

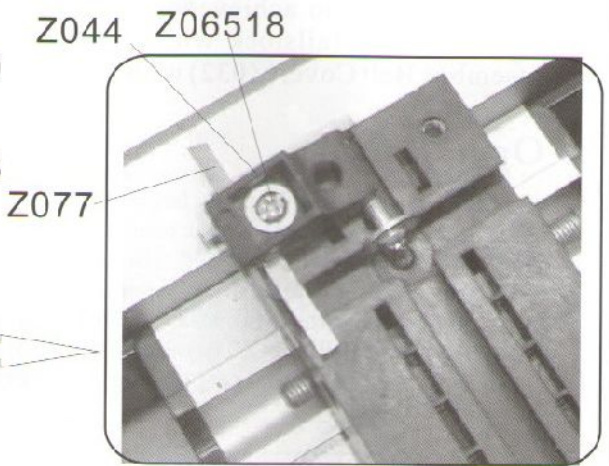
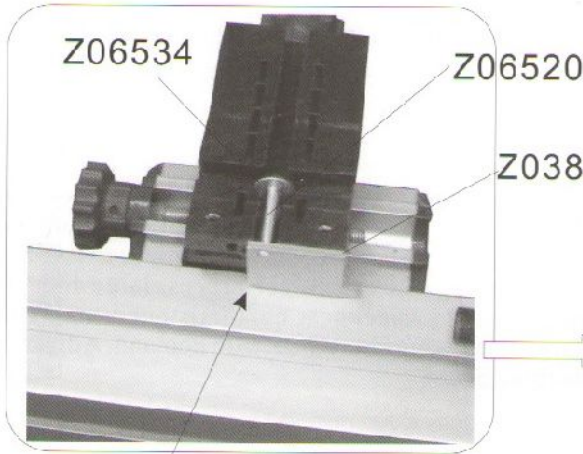
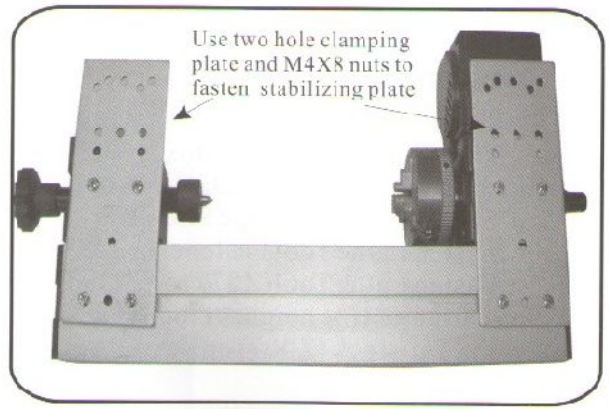
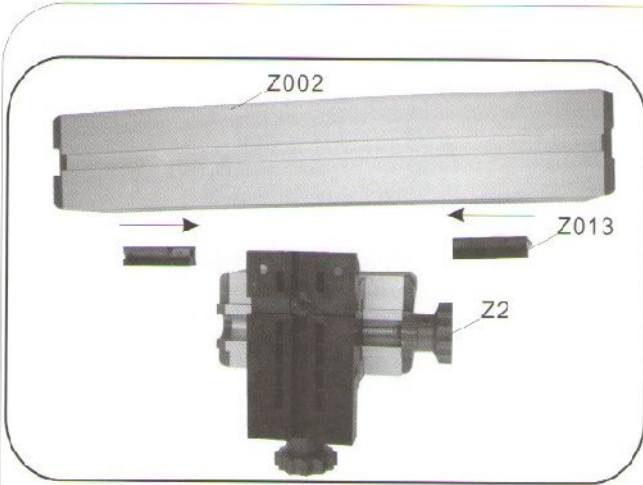

Install lathe tools fastener

Install Lathe

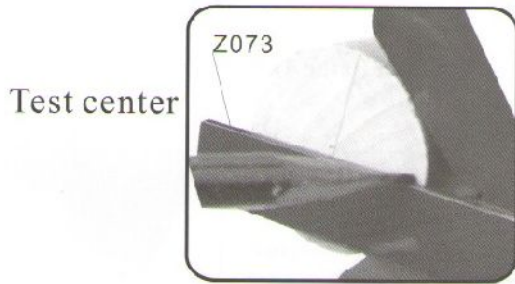

Test center

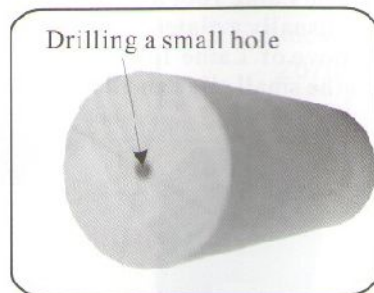

Drilling a small hole

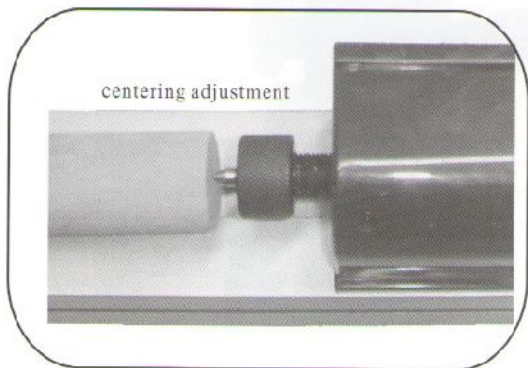

centering adjustment



Z071

Tighten screw when processing

## Woodturning Lathe (Z20003)

### Assembly:

As Shown Fig:

Fasten the Drive Center (Z016) into the Wheel Gear Box (Z004) by Collet (Z06106) and Collet Fixing Nut(Z045), Fix Motor-Wheel Gear Box unit (Z1) on the left of Long Machine Bed (Z002) by Dovetail Connecting Block (Z013).

Fix Small Slide-Large Slide unit (Z2) on the obverse of Long Machine Bed.

Fix Woodturning Support(Z033) on the Large Slide (Z009) with Slot Nut(Z042).

Fix tailstock (Z007) on the right of Long Machine Bed with Dovetail Connecting Block, screw LiveCenter (Z019) into tailstock.

Use the two fastener Stabilizing Plates (Z08001) to reinforce the connection of the machine on wheel gear box, long machine bed, tailstock with Two Holes Clamping Plate (Z043).

Fasten the Belt Cover (Z032) onto the motor to protect the drive belt in most situations.

### Operation:

Determine the center of round work piece with Center Finder (Z073).

Press the Drive Center (Z016) into the center of work piece with a hammer.

Use a Dia. 5mm drill bit for the center-hole of the other end (maximum depth 5mm).

After assembling the Driver Center and work piece, press Live Center (Z019) with hand, wheel of tailstock against work piece until it is firmed.

Tighten tailstock with Socket Screw Wrench (Z071) to avoid work piece dropping out. This will prevent the bolt of tailstock from loosing when it is in motion.

Woodturning Support (Z033) should be closed enough to the work piece, but without touching it. Press the Turning Gouge (Z078) on Woodturning Support and hold the handle of the Turning Gouge. Use your right hand holding the handle of the Turning Gouge at the lower position of the Woodturning Support.

Move the Turning Gouge to the left and to the right when working. If the stroke of Large Slide is too short to work on, adjust the position of the Large Slide Corresponding to the Long Machine Bed.

### Notices:

Always wear Protective Goggles when working with the machine

Never touch the revolving working piece with any part of your body and your clothes.

Never hold the handle of the Turning Gouge when it is positioned higher than the Woodturning Support.

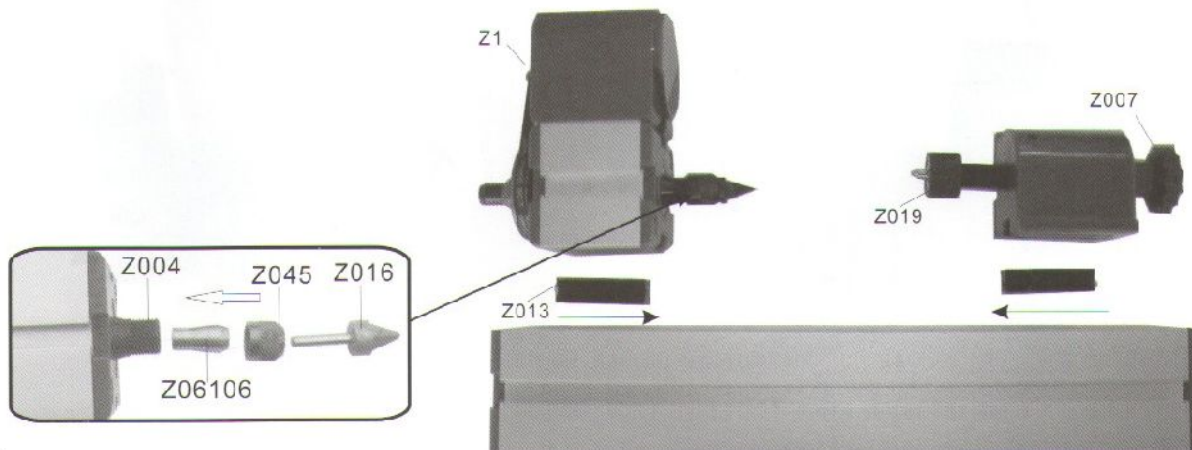

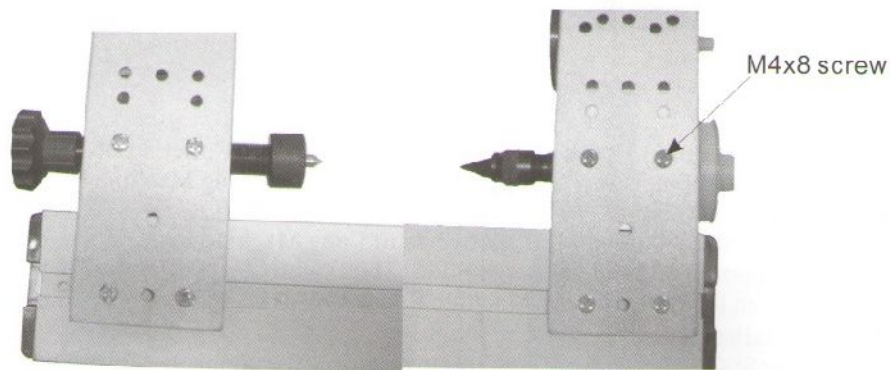

Install a stabilizing plate on gear box and long bed

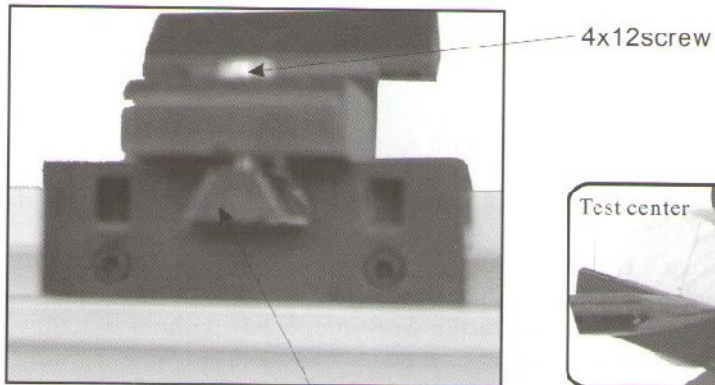

Single slot nut

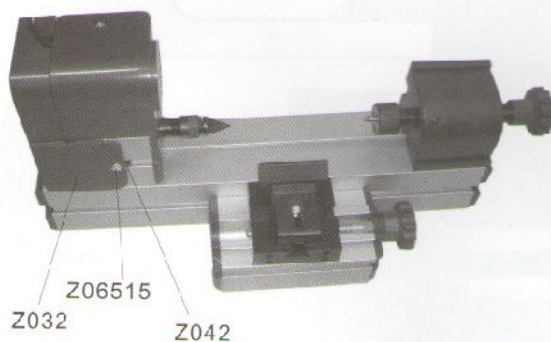
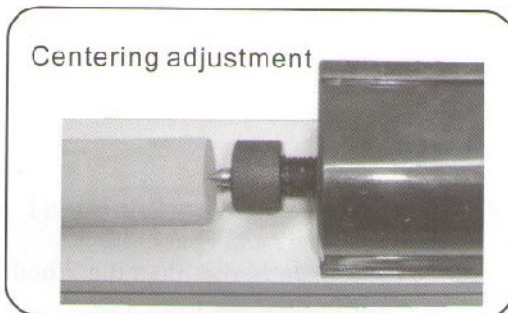
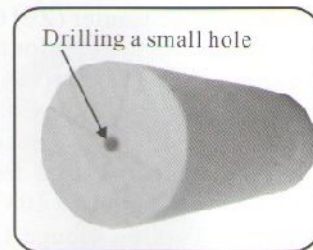

Woodturning Lathe



Processing workpiece

## Drilling Machine (Z20004)

### Assembly:

As Shown Fig:

First, screw into Two Hole Clamping Plate(Z043) with two 4X7 (Z06515) bolts, then slide the Two Hole Clamping Plate with two 4X6 bolts into the dovetail groove of Long Machine Bed(Z002), insert the two bolt heads into the pearshaped holes of Short Machine Bed(Z003) (insert them into bulge-like part of hole, then into neck-like part), firmly tighten screws through Short Machine Bed with Screwdriver(Z070), then place the Long Machine Bed vertically.

Fix the Drilling Table(Z026) on Small Slide-Large Slide unit(Z2) by using two Slot Nuts (Z043) with 4×12bolt(Z06518). Fix four Lathe Tool Fixer(Z044) on four corners of the Drilling Table.

Fix Motor-Wheel Gear Box unit(Z1) on Small Slide-Intermediate Piece unit(Z3) with two Dovetail Connecting Blocks(Z013), Fasten the Drilling Bit(Z07401) into the axle of Wheel Gear Box by using Collet(Z06106) and Collet Fixing Nut(Z045), then fix the whole unit on Long Machine Bed.

Turn the handle of Small Slide clockwise until stop, loosen Socket Screw on the handle with Socket Screw Wrench(Z071) until the handle can be moved free from the bolt axle of Small Slide, Stick on Drilling Lever (Z027) between the hole of Intermediate Piece and Small Slide. You may drive the Drilling Lever up and down while working.

### Operation:

As the stroke of Drilling Lever is limited, you may adjust the position of Intermediate Piece responding to Long Machine Bed with regarding to different working depth and work piece. Different drilling bits for different collets. Adjust the position of large slide responding to long machine bed if the stroke of large slide can not meet the working requirement. By tilting small slide, work piece can be drilled at some angle(See Fig )

Always wear Protective Goggles when working.

Never touch the revolving Drilling Bit with any part of your body and your clothes.

Never touch the revolving Drive Belt and Gear as the Drive Belt Cover is not assembled on the Motor-Wheel Gear Box unit(Z1) regarding drilling machine.

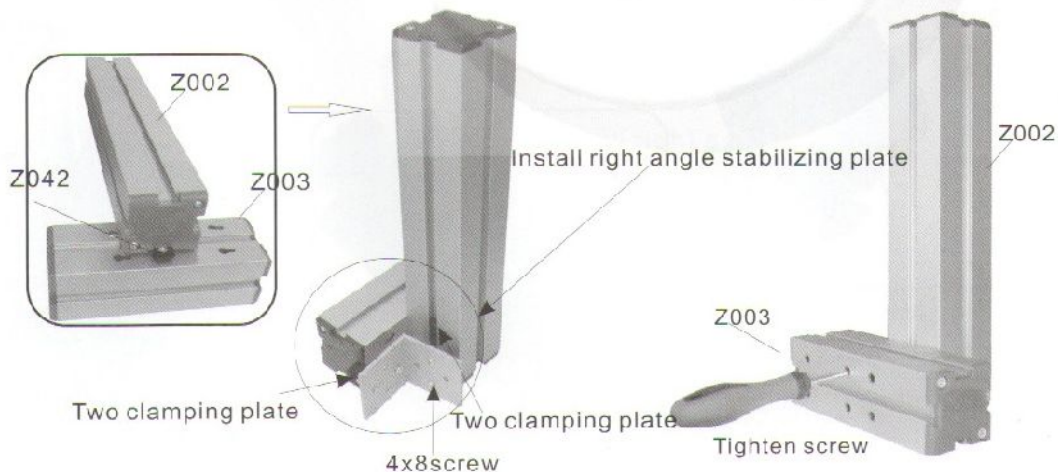

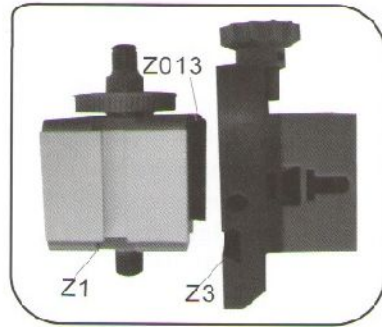
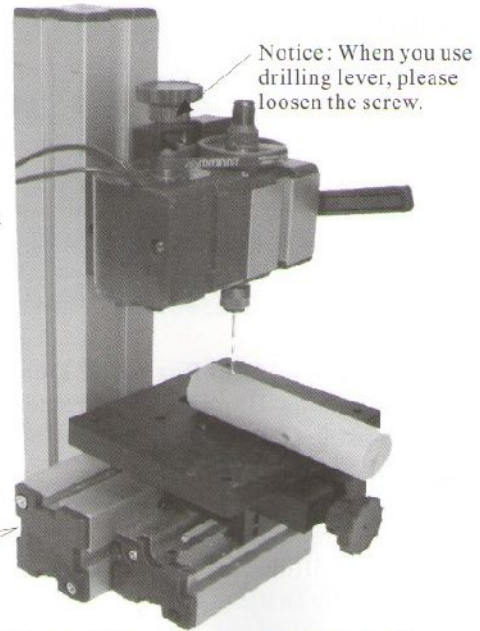
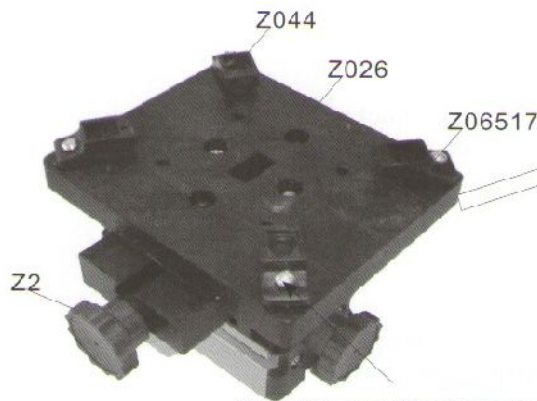

Fig.20



Drilling Machine (Z20004)



Remarks: According to yourself if need to choose whether to add lathe tool fixer.

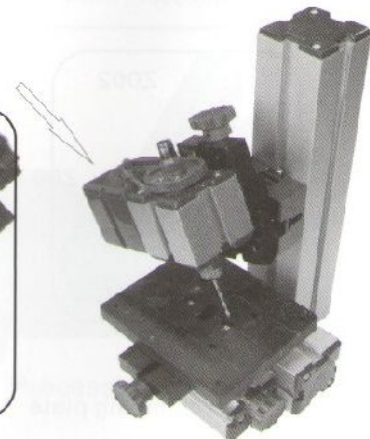
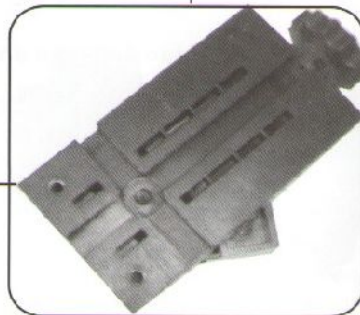
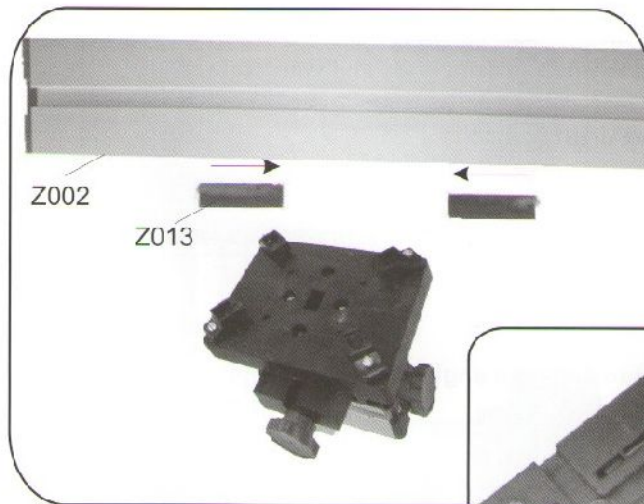
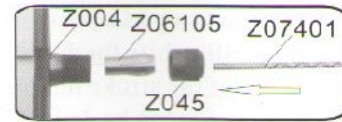

## Milling Machine (Z20005) :

### Assembly:

As Shown Fig:

Screw and slide the two 4x7 Bolts (Z06515) into Two Hole Clamping Plate (Z043) and the dovetail groove of the Long Machine Bed (Z002) respectively.

Insert the two bolt heads into the pear-shaped holes of Short Machine Bed (Z003).

The insertion must be straight through the bulge-like part of hole into the neck-like part.

Tighten the screws firmly with Screwdriver(Z070).

Hold the Long Machine Bed horizontally.

Fasten the Small Slide-Intermediate Piece unit (Z3) onto the Small Slide vertically with the Dovetail Connecting Block (Z013).

Fasten the Milling Tool (Z07501) into the axle of Wheel Gear Box by using Collet (Z06104) and Collet Fix Nut (Z045).

Ensure the whole unit(Z1) fix on the Small Slide-Intermediate Piece unit firmly.

Connect the machine Vice (Z012) to the Small Slide-Large Slide(Z2) unit with Dovetail Connecting Block. Connect the Small Slide-Large Slide unit to the Long Machine Bed obverse with Dovetail Connecting Block.

### Operation:

Adjust the position of the Intermediate Piece in corresponding to the Long Machine Bed to accommodate different working depth and the height of the work piece.

Use different Milling Tool bits with different Collets (Z061)

When the stroke of the Large Slide is insufficient, adjust the position of the Large Slide in corresponding to the Long Machine Bed.

By tilting Small Slide, work piece can be milled at some angle as shown in the diagram. And also can assemble this machine into vertical milling machine referring to the assembling of drilling machine.

You can process dividing with the Three-jaw Chuck(Z011) ,Dividing Positioner(Z022) and Dividing Attachment(Z023).

### Notices:

Always wear Protective Goggles(Z040) when operating the machine.

Never touch the revolving working piece with any part of your body and your clothes.

Be aware of the danger of the Milling Tool as the Bit is very sharp.

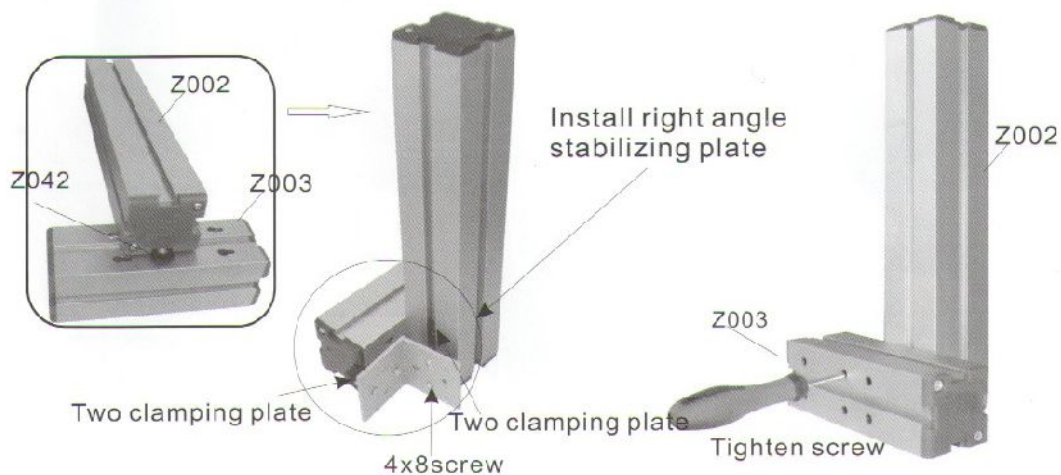



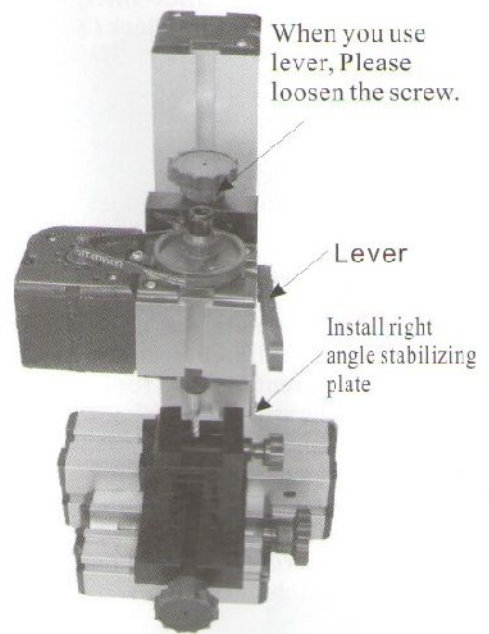
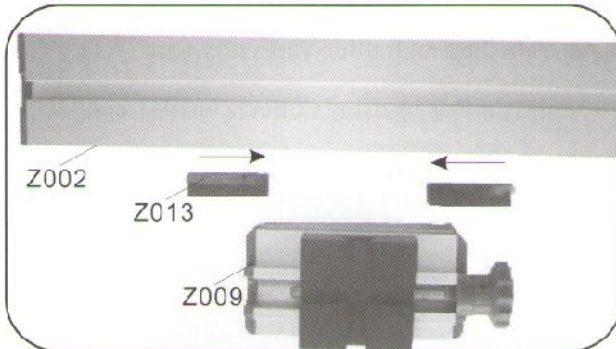
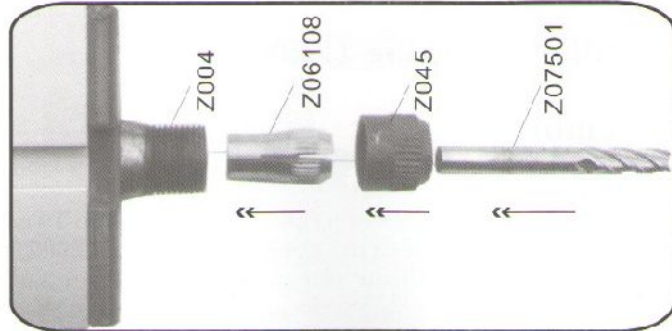
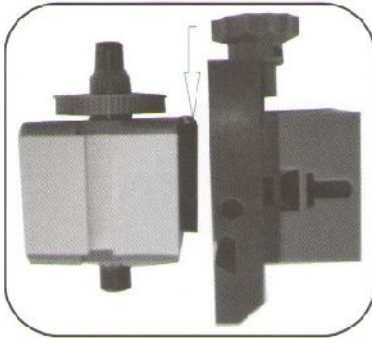

Vertical milling machine

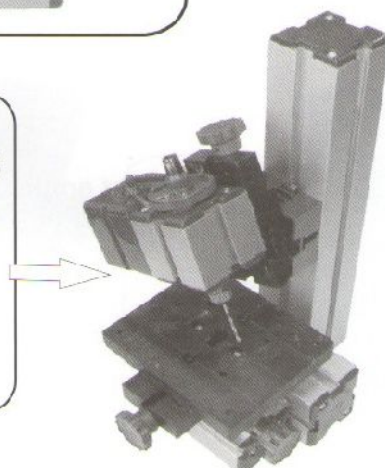
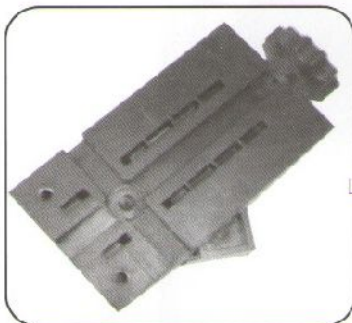
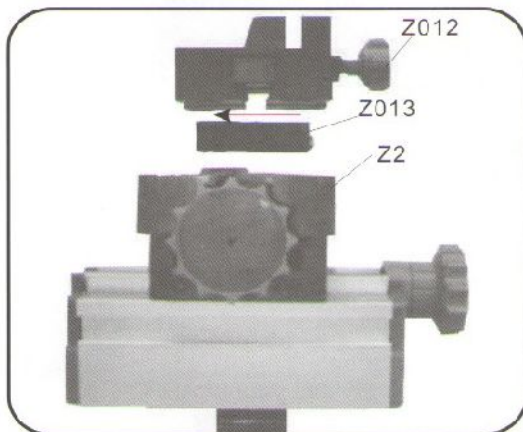

Oblique drilling(milling)

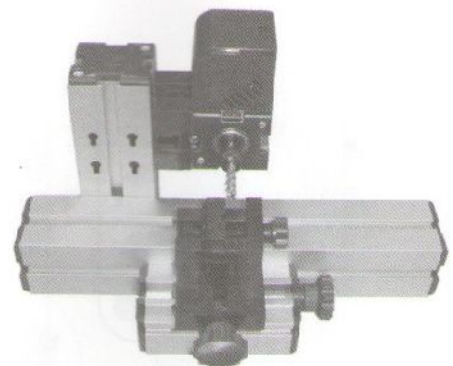

Horizontal milling machine

## Sanding Machine (Z20006) :

### Assembly:

As shown Fig: Connect the Motor-Wheel Gear Box Unit (Z1) to the left of Long Machine Bed (Z002) with Dovetail Connecting Block(Z013).

Adhere the Sanding paper (Z024)(with pressure-sensitive adhesive in the back) to the Clamping Plate (Z017).

Screw the Clamping Plate into the Axle of Wheel Gear Box(Z004).

Use the Slot Nut (Z042) to connect the Drilling Table (Z026) to the top of the Long Machine Bed near to the Sanding Paper.

Adhere the Grinding Wheel(Z01801) on the Grinding Wheel Assy(Z01802).

Insert the Grinding Wheel and its accessories into the end of the Axle of Wheel Gear Box .Ensure the flange of Grinding Wheel Assy corresponds to the groove of Wheel Gear Box .

Connect the Grinding Wheel Cover(Z034) to the Grinding Wheel Cover Connection (Z035) with two 3x10 Bolts (Z06504).

Install the unit on Wheel Gear Box with Slot Nut(Z042).

### Operation:

Ensure the Tools to be sanded aligns with the axis of grinding wheel while grinding.

Sand workpiece with sanding paper adhering.

Observe the direction of workpiece movement and it must be opposite towards Rotating direction of grinding wheel.

### Notices:

Always wear Protective Goggles(Z040) when working with the machine.

Never touch the revolving working piece with any part of your body and your clothes.

Never dismantle Grinding Wheel Cover for avoiding accidents while working.

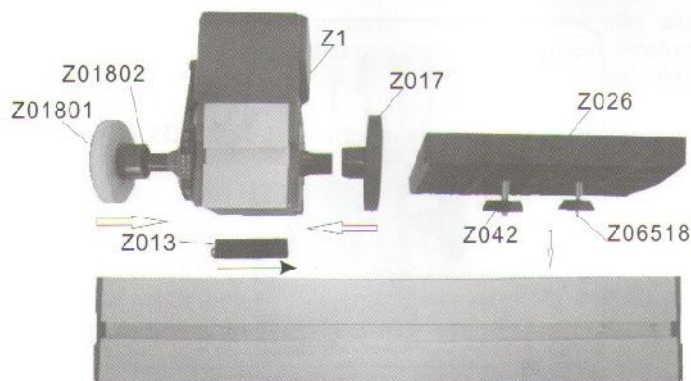

Grinding Tools

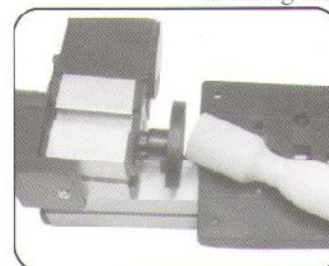
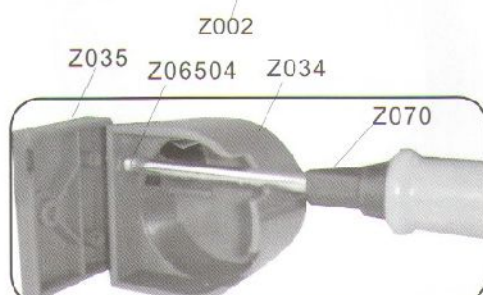

Hand-held Machine (Z10001)

**Assembly:**

As Shown Fig:

Fix Belt Cover(Z032) on Motor-Wheel Gear Box unit(Z1). Screw Clamping Plate (Z017) into the axle of Wheel Gear Box. Stick on Clamping Plate with Sanding paper (Z024).

You may use Collet and Collet Fixing Nut instead of Clamping Plate, when Drilling Bit(Z07401) is assembled, you will get a "hand" drilling machine; similarly, you will get "hand" grinding machine, "hand" milling machine etc.

**Notices:**

Always wear Protective Goggles(Z040) when working.

Never touch the revolving working piece with any part of your body and your clothes.

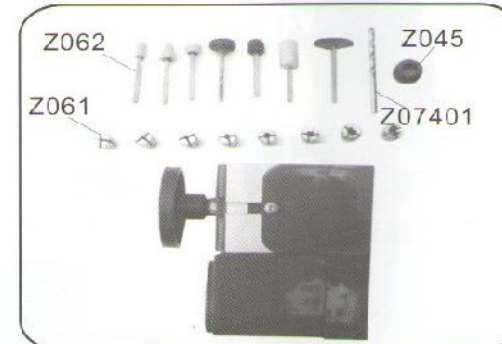
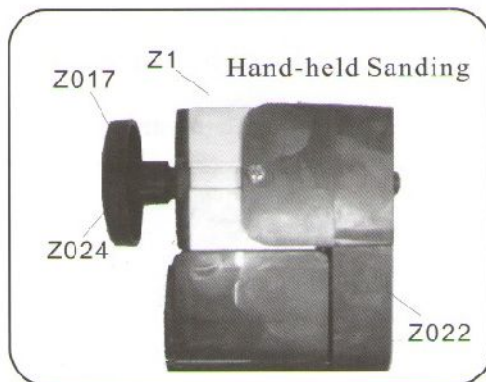

## Drilling Machine With Dividing Attachment (Z10002)

### Assembly:

As shown Fig:

Slide two 4×7 Bolts(Z06515) into Two Hole Clamping Plate(Z043) .Put this Two Hole Clamping Plate with two 4X7 bolts into the dovetail groove of Long Machine Bed(Z002), insert the two bolt heads into the pearshaped holes of Short Machine Bed(Z003 )(insert them into bulge-like part of hole, then into neck-like part), firmly tighten screws through Short Machine Bed with Screwdriver(Z070), then place the Long Machine Bed vertically.

Fix Small Slide-Larger Slide unit(Z2) on Short Machine Bed with two Dovetail Connecting Blocks(Z013).

Fix Wheel Gear Box (Z004)on Small Slide-Larger Slide unit(Z2) with two Dovetail Connecting Blocks, the end with Gear Wheel of Wheel Gear Box must be pointed to the right as shown Fig.25.

Fasten Dividing Attachment Positioner(Z022) on Wheel Gear Box with Slot Nut (Z042) and 4×12 Bolt(Z06518) , Screw into two hole of Three-Jaw Chuck(Z011) reverse with two 3X10 screws (Z06504), then insert the two screw heads into the pearshaped holes of Dividing Attachment (Z023)(insert them into bulge-like part of hole, then turn into neck-like part), firmly tighten screws with Screwdriver. Screw three jaw chuck into the axle of Wheel Gear Box, adjust the position of Dividing Attachment Positioner until the mandrel of dividing attachment Positioner can be aligned to the small hole on Dividing Attachment.

Fix Motor-Wheel Gear Box unit(Z1) on Small Slide-Intermediate Piece unit, fasten the Drill Bit (Z07401) into the axle of Wheel Gear Box by using Collet(Z06106) and Collet Fixing Nut(Z045), then fix the whole unit on Long Machine Bed with Dovetail Connection Piece.

Turn the handle of Small Slide clockwise until stop, loosen Socket Screw on the handle with Socket Screw Wrench(Z071) until the handle can be moved free from the bolt axle of Small Slide, stick on Drilling Lever (Z027) between the hole of Intermediate Piece and Small Slide. You may drive the Drilling Lever up and down while working.

### Operation:

Clamp work piece with Three-Jaw Chuck tightly. There are three rings of small holes(36,40, 48) around Dividing Attachment, Select the hole ring responding to working demand. For example, if you need to drill 10 equivalent dividing holes around the work piece, choose the ring with 40 holes and catch in the mandrel, bore in a hole, move the dividing attachment 4 holes further, make mandrel catch in again and bore another hole, then repeat this process ten times, you may get your need.

As the stroke of Drilling Lever is limited, you may adjust the height of Intermediate Piece on Long Machine Bed regarding to different working depth and workpiece.

Adjust the position of Large Slide on long machine bed if the stroke of Large Slide can not meet the demand for the workpiece.

By tilting Small Slide, workpiece can be drilled at some angle.

### Notices:

Always wear Protective Goggles(Z040) when working.

Never touch the revolving drilling bit with any part of your body or your clothes.

Never touch the revolving Belt and gear as the Belt Cover is not assembled on the Motor-Wheel Gear Box unit(Z1) regarding drilling machine.

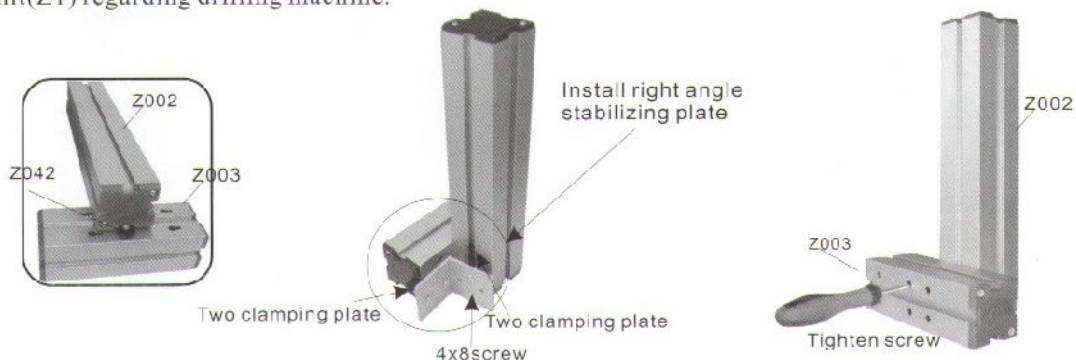

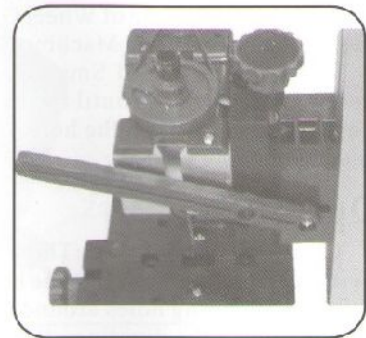
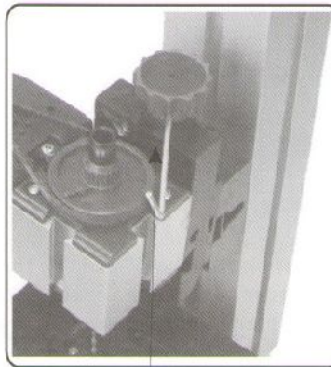
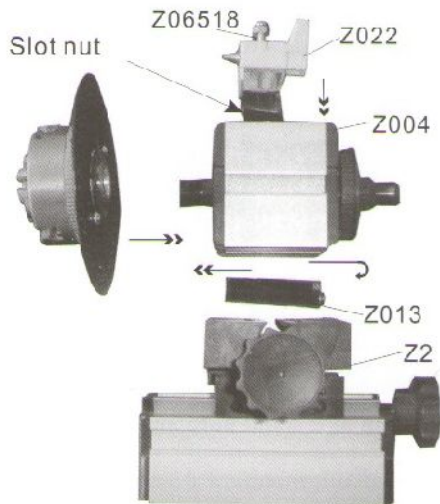

use drilling lever, Please loosen the screw.

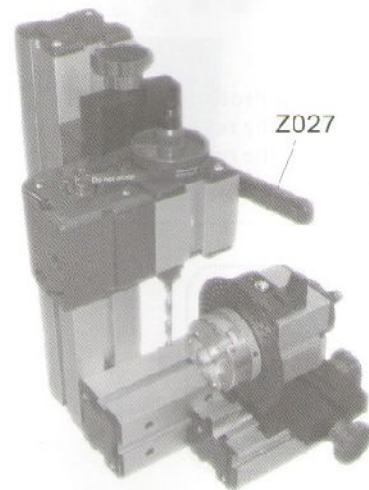
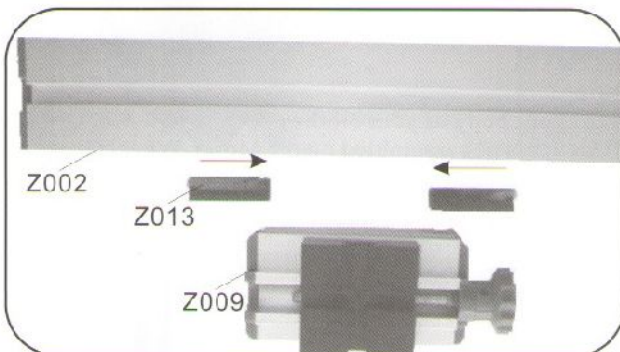

Drilling Machine With Dividing Attachment (Z10002)

## How to fasten the machine

### Method 1:

As Shown Fig.28 : Slice Two Hole Clamping Plate into dovetail groove of Short/Long Machine Bed at both ends of machine bed, but half section of Two Hole Clamping Plate should be discovered; fasten the Two Hole Clamping Plate on the wood board or table with 3X10 Screw (Z06504) by Screwdriver(Z070) so that you may work steadily.

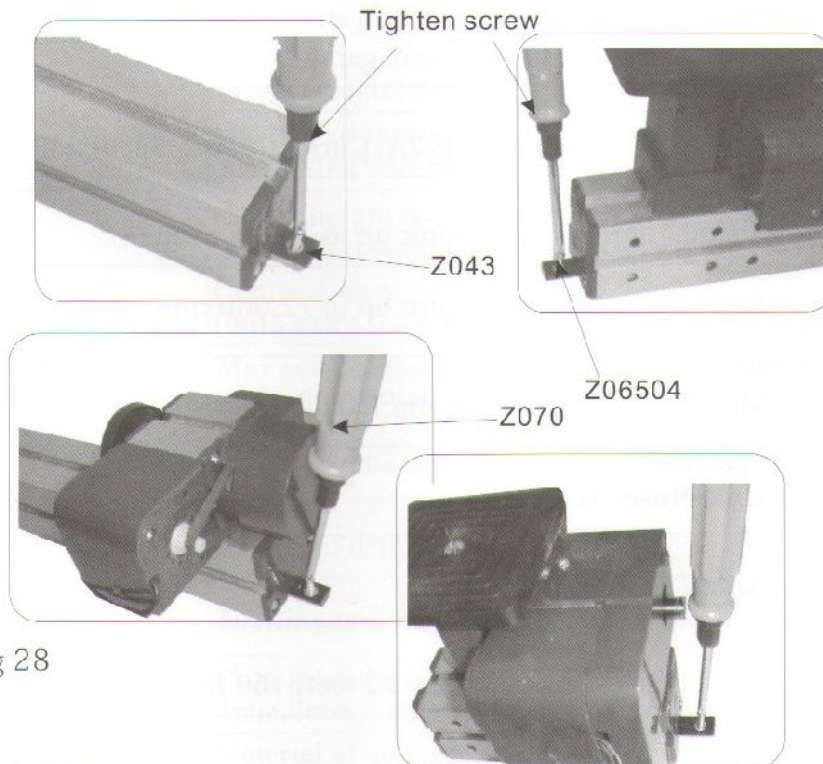
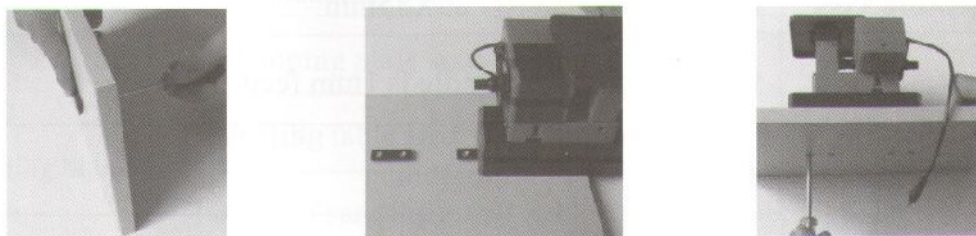

Fig 28

### Method 2:

If we have the baseplate, firstly, we use screws to fasten two hole clamping plate to the baseplate, secondly, slide the dovetail groove of machine base along the two hole clamping plate, at last, tighten the screws.



## Important Data

Description	Important Data
Power Adaptor	Prim.Input Voltage:220V~240V,50~60Hz/110V~120V,50Hz~60Hz
	Sek.Output Voltage:12V DC,Direct Current :2A,Power Supply:24W
	With thermostat protector
Motor	12V DC,Power input up to 2A. Current/Power Supply:500mA/6W
	Speed of high speed motor up to 20,000 rpm
	Speed of Low speed motor up to 12,000 rpm
	Motor Leaf's slice gear rim: 10 teeth
Wheel Gear Box	Axle Nose: M12X1
	Hole Through Axle:8mm
	Wheel Gear Box gear rim: 23 teeth /60 teeth
	Bearing:Ball Bearing
Tailstock	Axle Nose:M12X1,Travel of tailstock: 15mm
Machine Vice	Clamping Capacity: 25X35mm
Small/Large Slide	One turn with the handle is 1mm feed
	Travel of small slide:30m m
	Travel of large slide:50mm

Description	Important Data
Jigsaw	Stroke of saw blade: 4 mm
	Material and max. depth of cut: balsa 18mm, plywood 7mm, hard wood 4 mm , plexi -glass 2 mm , aluminium plate 1 mm
Lathe	Center height from the machine bed : 25 mm , (with intermediate piece can be heighten to 50mm )
	Center distance : 135mm , (with extra long machine bed can be longer to 365mm )
	Max . cutting diameter : 20mm (bigger diameter up to 50mm is possible with intermediate piece )
	Material of turning: any kind of wood (hard wood will be better ) Soft metal (such as gold , silver, aluminium etc.)
Woodturning lathe	Center height from the machine bed : 25 mm , (with intermediate piece can be heighten to 50mm )
	Center distance: 135 mm , (with extra long machine bed can be longer to 365mm )
	Max cutting diameter, (bigger diameter up to 50 mm is possible with intermediate piece )
	Material of turning : any kind of wood (hard wood will be better )
Drilling Machine	Travel of drilling lever: 25mm
	Drilling table size: 123×100mm
	Collet clamping size for drill bit: 1mm, 2mm, 2.5mm, 3mm, 3.5mm, 4mm, 5mm, 6mm .
	Material of drilling: any kind of wood (hard wood will be better ) Soft metal (such as gold , silver, aluminum etc.)
Milling Machine	Collet clamping size for milling cutter: 1mm , 2mm, 2.5mm, 3mm, 3.5mm, 4mm, 5mm, 6mm.
	Material of milling : any kind of wood (hard wood will be better ) Soft metal (such as gold , silver, aluminium etc.)
Sanding Machine	Clamping plate size: Dia. 50mm
	Drilling table size : 123×100mm
	Grain of sanding paper : 100 # or choose other you need
	Material of sanding: any kind of wood (hard wood will be better ) Soft metal (such as gold , silver, aluminium etc.)



Description	Important Data
Hand-held Machine	Clamping plate size: Dia.50mm
	Grain of sanding paper: 100# or choose other you need
	Collet clamping size for drill bit: 1 mm,2mm,2.5mm,3mm,3.5mm,4mm,5mm,6mm .
	Material of processing: any kind of wood(hard wood will be better) Soft metal(such as gold, silver,aluminium etc.)
Drilling Machine With Dividing Attachment	Travel of drilling lever: 25mm
	Collet lamping size for milling cutter: 1mm,2mm,2.5mm,3mm,3.5mm,4mm,5mm,6 mm.
	three rings of small holes(36,40,48) around dividing attachment
	workpiece diameter up to 50mm
	Material of drilling: any kind of wood(hard wood will be better) Soft metal(such as gold, silver,aluminium etc.)

## Trouble Shooting

No.	Malfunction	Analyzation	Trouble Shooting
1	Motor does not work when power is connected	Power socket(110/220V)is not connected rightly or no power output	Check and make sure power is connected
		socket of power apaptor or power supply connector is broken off	check the wire connection with manual guide
		fuse of adaptor is broken off	replace adaptor
		motor wire is broken	check the wire connection with manual guide
		Motor is broken off	Replace motor
		tension of drive belt is too tightly,and stop the motor	adjust the tension again base on the manaul
		take down the drive belt,then turn on the motor switch; the axle of wheel gear box maybe get stuck if the motor run normally	take down the wheel gear box, grease the bearing or replace it if the wheel gear box is not rotating normally
see if it does not run after clamping the workpiece, check again after taking down the workpiece	Tension of drive belt is too tightly,and stop; or see if some thing resist the workpiece		
2	Noise is loudly when running	the connecting block is loosen	check the connecting block is screwed tighly or not with manual guide
		tension of drive belt too tightly or too loosen will cause loudly noise	adjust the tension again with the manual guide
		maybe the axes of workpiece is not superposition with thc the axes of wheel gear box	reassemble the workpiece until the axes is superposition
		carbon brush of motor is worn off	replace motor
		the moving parts is not greased enough for long time	grease the moving parts right now with manual guide
3	Feed back hardly	Accumulate too many dust to Support the feedback	Clean on time
		screw of slide is seldom greased	grease the connection
		adjustable bolt of slide is screwed too tightly	adjust base on manual, for too loosen or tightly can be effected the precision
4	Stop suddenly when working	fuse of power adaptor is broken off	Replace power adaptor
		carbon brush of motor is worn off	Replace motor
		Motor is broken off	Replace motor

No.	Malfunction	Analyzation	Trouble Shooting
5	Jigsaw is cutting hardly	working piece too thick or improper force direction	read the concerned pages in manual carefully before working
		forward direction of working piece is not right towards the saw blade teeth	read the concerned pages in manual carefully before working
		belt is worn out for long time working	replace the belt
		cam is worn out	replace the cam
		the axle of jigsaw case is worn out	maintain or replace the axle of jigsaw case
		saw blade is worn off for long time cutting	replace the saw blade
6	Saw blade is broken	improper force direction or saw blade is assembled loose	See the manual, reassemble the saw blade. (saw blade is used up to 3 times)
7	Turning Hardly in lathe	feed back too fast	feed back slowly for beginner until you get more experience, different material for different feedback.
		knifepoint of tool is not positioned at the rotation center of work piece	adjust the height of tool until the knifepoint is positioned at the rotation center of work piece.
		turning tool is not sharp	often sharp the tool and sharp the right angles of tool-edge
		Belt is worn out for long time working	replace the belt
		axle of tailstock or live center is loosen	adjust the position of tailsock and live center in the right way (see the manual), screw the bolt of tailstock tightly
8	Turning hardly in woodturning lathe	feed back too fast	feed back slowly for beginner until you get more experience, different material for different feedback.
		knifepoint of gouge is not positioned at the rotation center of work piece	place the gouge on the woodturning support, knifepoint of tool is position at the rotation center of work piece
		gouge is not sharp	often sharp the tool and sharp the right angles of tool-edge
		drive belt is worn out for long time working	replace the drive belt
		axle of tailstock or live center is loosen	adjust the position of tailsock and live center in the right way (see the manual), screw the bolt of tailstock tightly