

- 采用热塑性外壳，结构紧凑，安装方便；
Adopt thermoplastic crust, compact construction, and simple installation;
- 可加装防护套，能防油、防尘；
May install the protecting cap, can against oil and dustproof;
- 有手动复位与自动复位，灵活选择；
Hand reset and automatic reset for flexible choice;
- 广泛应用于各种电子设备、自动化设备、通讯设备、仪器仪表等领域作电源通断与连接电路用。
Widely used in Electrical equipment, automatic machine, communication equipment and instrument, electro motion tool etc.

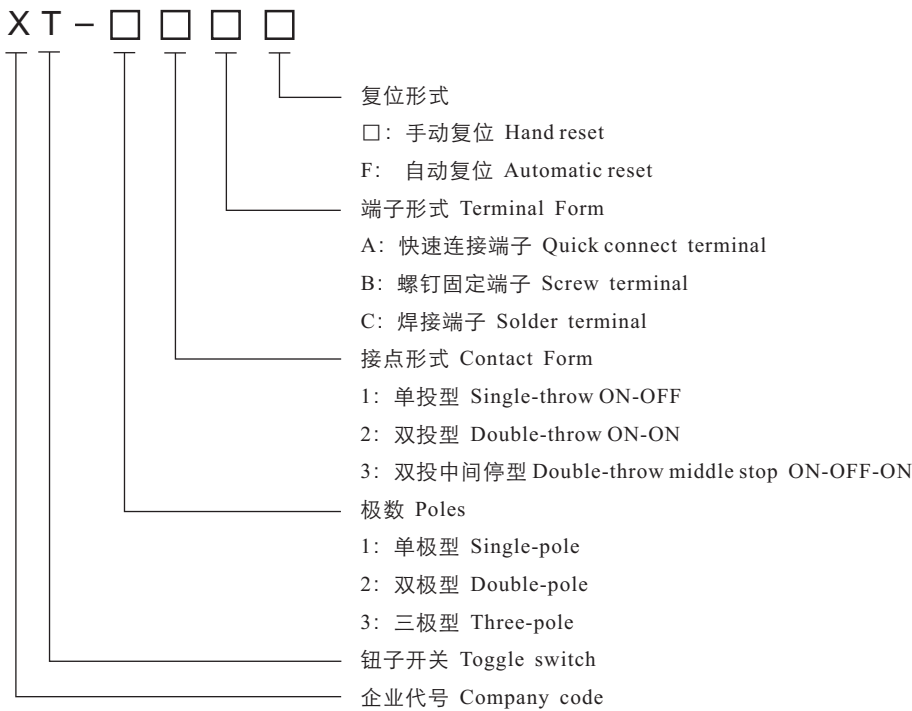

◆ 型号含义 Model & Meanings



◆ 安装孔尺寸及结构图 Mounting Holes & Product Structure

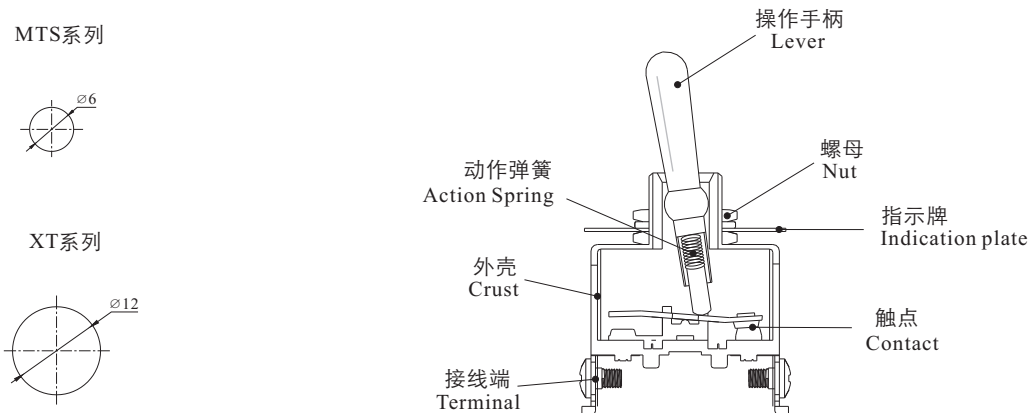

◆性能参数 Specification

项 目	Item	参数值	Data	
额定负载	Rating load	15A/250VAC, 25A/250VAC	MTS : 6A/125, 250V	
操作频率	Operation frequency	30次/分	30times/min	
绝缘电阻	Insulation resistance	100MΩ以上	(Above) DC500V	
接触电阻	Contact resistance	25mΩ	(初值 initial value)	
介质耐压	Withstand voltage	非连线	Non-connection wire	1000VAC
		各端子间	Every terminal	1500VAC
振 动	Vibration	误 动作	Misoperation	10-55Hz 复振幅 Amplitude 1.5mm
冲 击	Impact	耐 久	Durable	1000m/s ²
		误 动作	Misoperation	300m/s ²
寿 命	Life	电 气	Electrical	100,000次以上 above
		机 械	Mechanical	500,000次以上 above
防护等级	Protection degree	IP40		
使用温度	Operating temperature	-25~+80℃		
使用湿度	Operating humidity	<85%		

◆端子类型 Terminal Forms

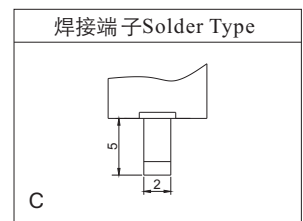
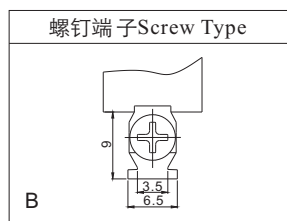
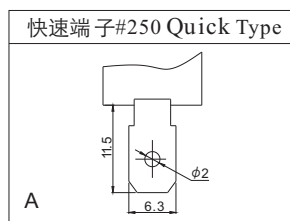
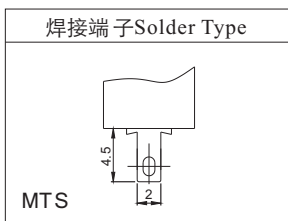

◆外形尺寸 Dimensions

- 单极双投型 SPDT ON-ON
MTS-102

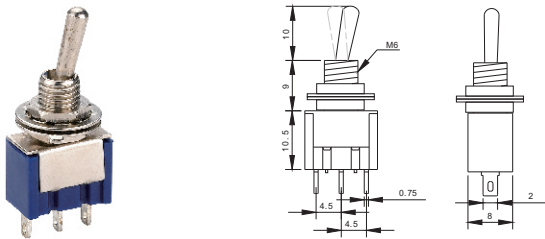

- 双极双投型 DPDT ON-ON
MTS-202

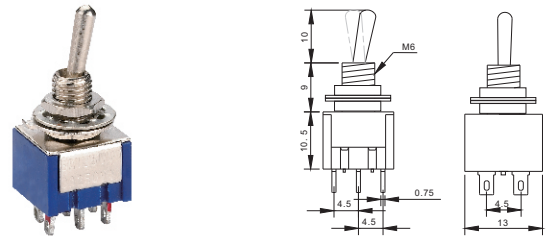

- 单极双投中间停型 SPDT ON-OFF-ON
MTS-103

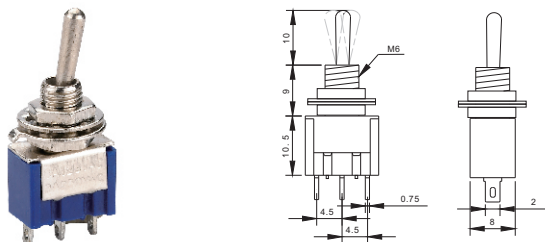

- 双极双投中间停型 DPDT ON-OFF-ON
MTS-203

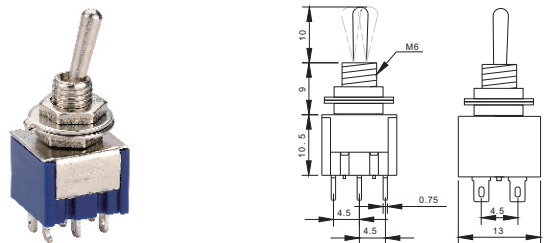

• 单极单投型 SPST ON-OFF
XT-11B

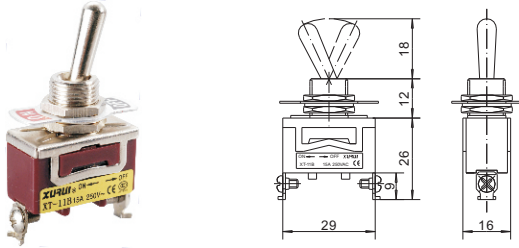

• 双极双投中间停型 DPDT ON-OFF-ON
XT-23B

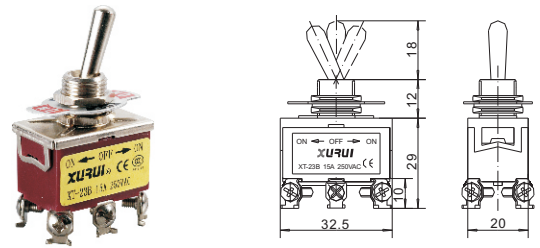

• 单极双投型 SPDT ON-ON
XT-12B

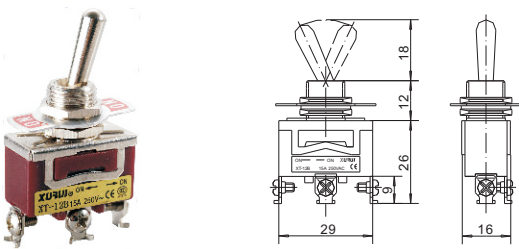

• 单极单投型 SPST ON-OFF
XT-11A

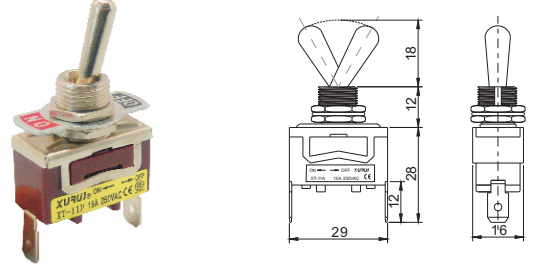

• 单极双投中间停型 SPDT ON-OFF-ON
XT-13B

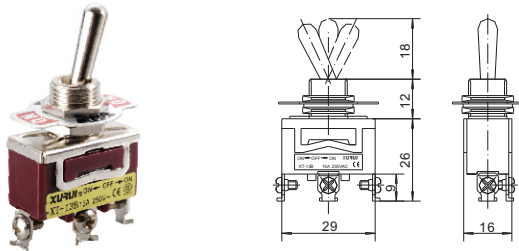

• 单极双投型 SPDT ON-ON
XT-12A

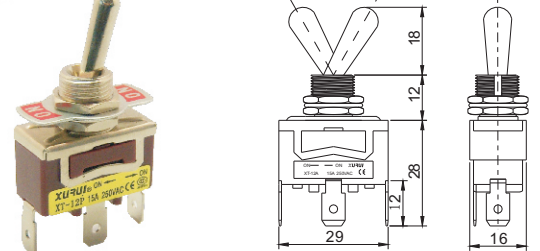

• 双极单投型 DPST ON-OFF
XT-21B

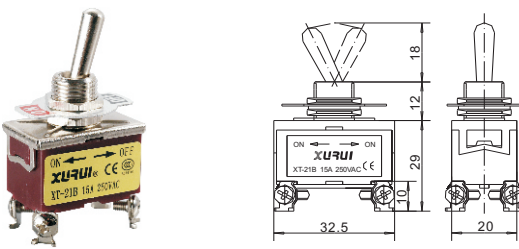

• 单极双投中间停型 SPDT ON-OFF-ON
XT-13A

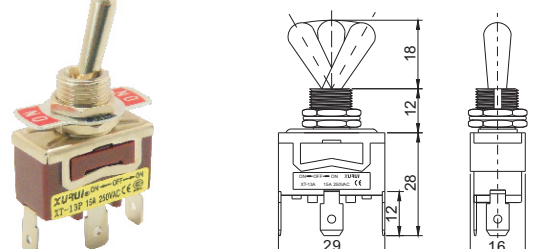

• 双极双投型 DPDT ON-ON
XT-22B

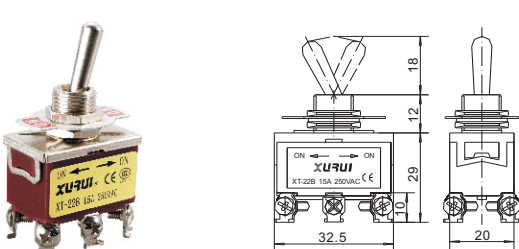

• 双极单投型 DPST ON-OFF
XT-21A

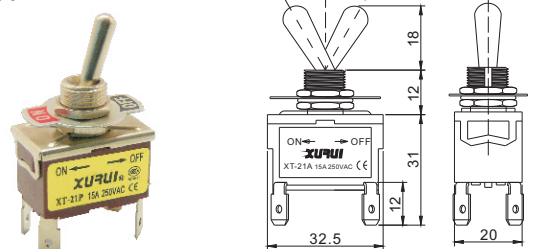

• 双极双投型 DPDT ON-ON
XT-22A

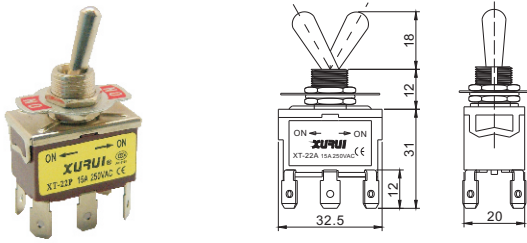

• 双极双向自动复位型 DPDT Auto Reset (ON)-OFF-(ON)
XT-23BF

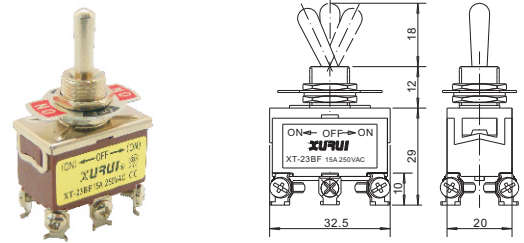

• 双极双投中间停型 DPDT ON-OFF-ON
XT-23A

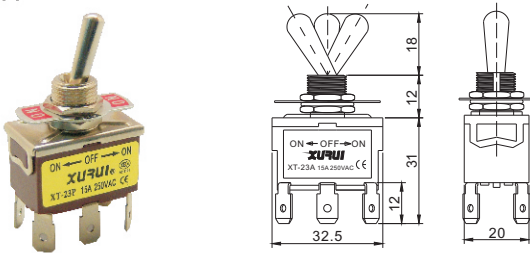

• 单极单向自动复位型 SPST Auto Reset (ON)-OFF
XT-11AF

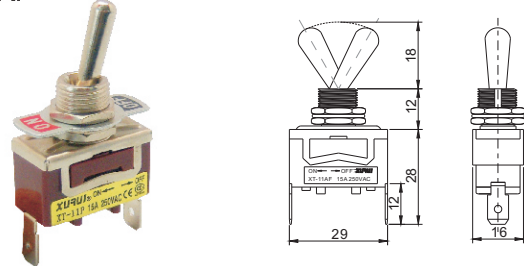

• 单极单向自动复位型 SPST Auto Reset (ON)-OFF
XT-11BF

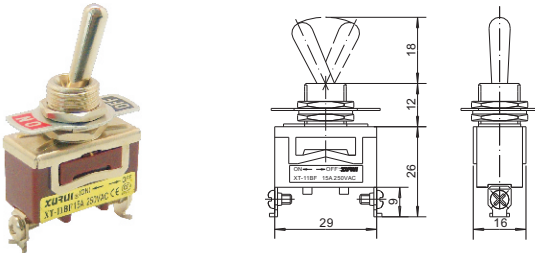

• 单极双向自动复位型 SPDT Auto Reset (ON)-OFF-(ON)
XT-13AF

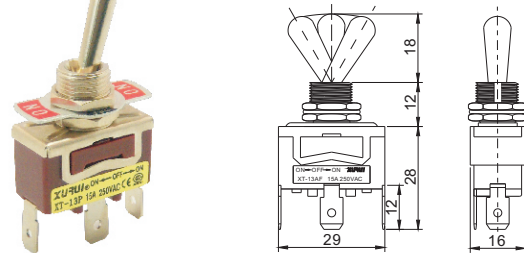

• 单极双向自动复位型 SPDT Auto Reset (ON)-OFF-(ON)
XT-13BF

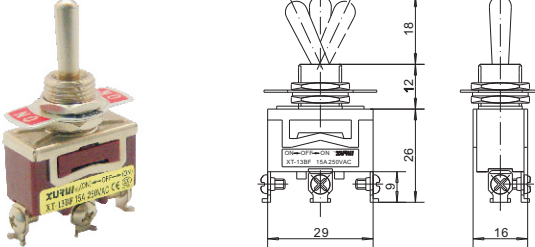

• 双极单向自动复位型 DPST Auto Reset (ON)-OFF
XT-21AF

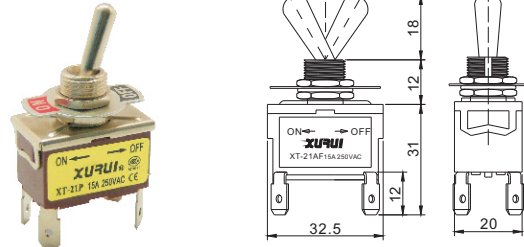

• 双极单向自动复位型 DPST Auto Reset (ON)-OFF
XT-21BF

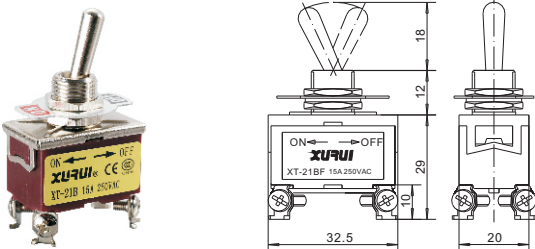

• 双极双向自动复位型 DPDT Auto Reset (ON)-OFF-(ON)
XT-23AF

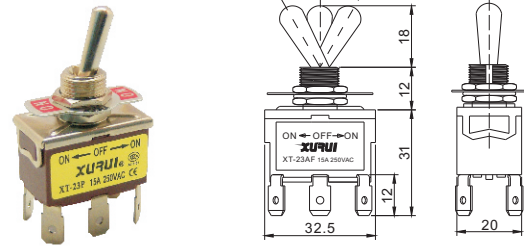

• 单极单投型 SPST ON-OFF
XT-11C

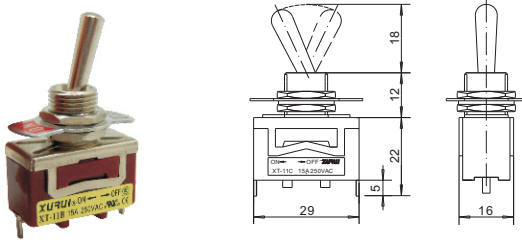

• 双极双投中间停型 DPDT ON-OFF-ON
XT-23C

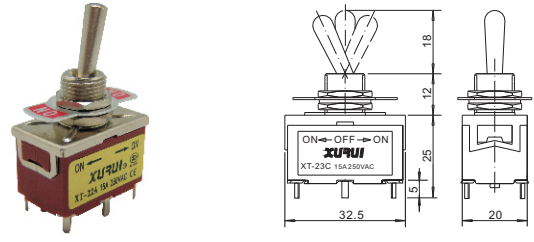

• 单极双投型 SPDT ON-ON
XT-12C

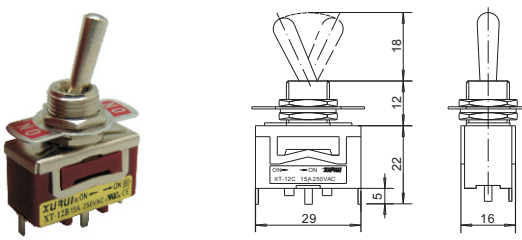

• 单极单向自动复位型 SPST Auto Reset (ON) -OFF
XT-11CF

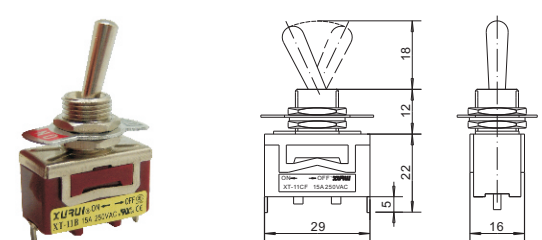

• 单极双投中间停型 SPDT ON-OFF-ON
XT-13C

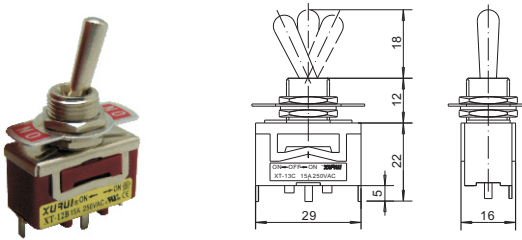

• 单极双向自动复位型 SPDT Auto Reset (ON) -OFF-(ON)
XT-13CF

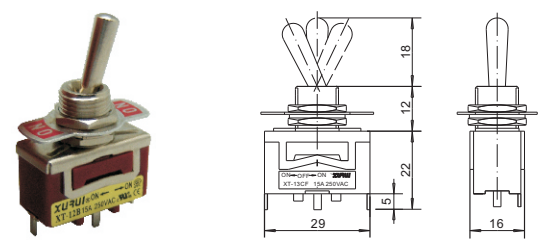

• 双极单投型 DPST ON-OFF
XT-21C

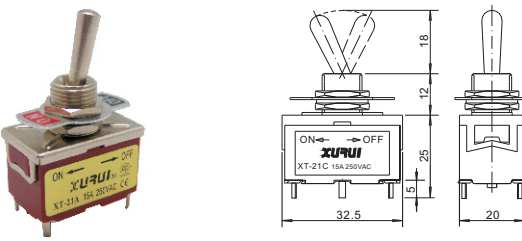

• 双极单向自动复位型 DPST Auto Reset (ON) -OFF
XT-21CF

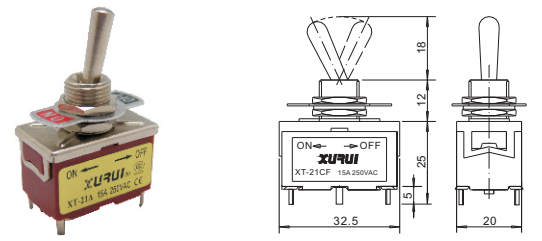

• 双极双投型 DPDT ON-ON
XT-22C

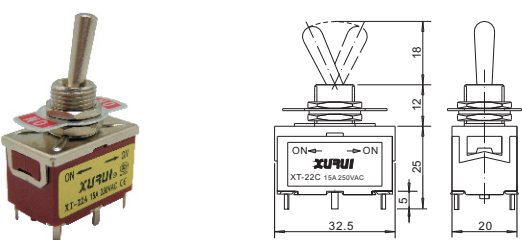

• 双极双向自动复位型 DPDT Auto Reset (ON) -OFF-(ON)
XT-23CF

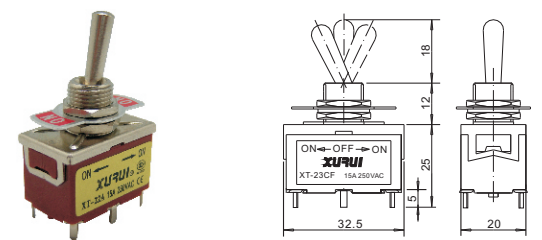

• 三极单投型 TPST ON-OFF
XT-31B

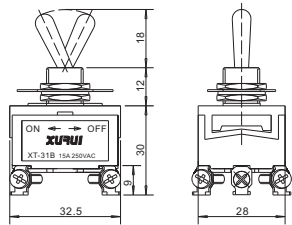

• 三极单投型 TPST ON-OFF
XT-31A

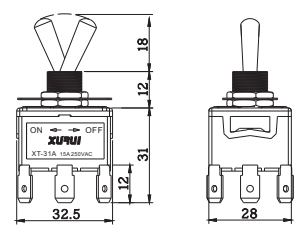
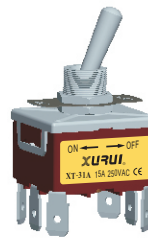

• 三极双投型 TPDT ON-ON
XT-32B

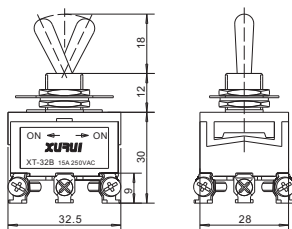

• 三极双投型 TPDT ON-ON
XT-32A

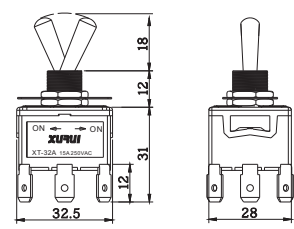
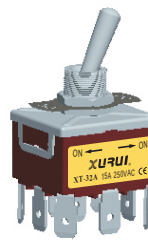

• 三极双投中间停型 TPDT ON-OFF-ON
XT-33B

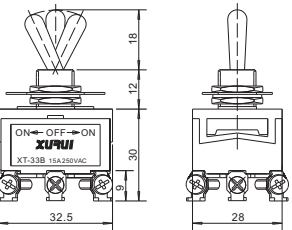

• 三极双投中间停型 TPDT ON-OFF-ON
XT-33A

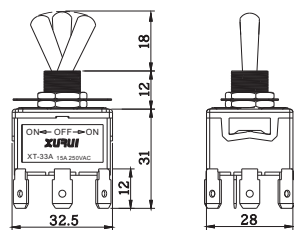
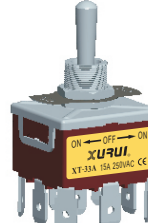

• 三极单向自动复位型 TPST Auto Reset (ON)-OFF
XT-31BF

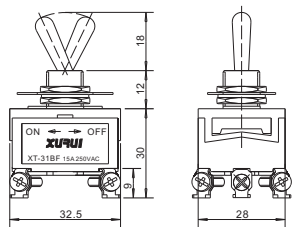

• 钮子开关防护套 Protecting Cap
XT-HT (M12x1)

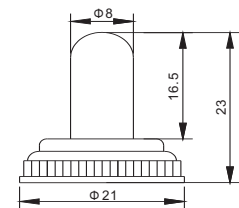

• 三极双向自动复位型 TPDT Auto Reset (ON)-OFF-(ON)
XT-33BF

